

# RMF SYSTEMS

PURE POWER



CONDITION  
MONITORING CENTER



# Condition Monitoring Center

## WHERE CAN IT BE USED?

- ▶ Renewable energy
- ▶ Gearbox applications
- ▶ Automotive industry
- ▶ Paper industry
- ▶ Offshore systems
- ▶ Lubrication systems
- ▶ Marine thrusters
- ▶ Test Benches

RMF SYSTEMS CONDITION MONITORING CENTER (CMC) COMBINES TECHNOLOGY TO ENABLE SAMPLING ON LOW PRESSURE HYDRAULIC AND LUBRICATION SYSTEMS WHERE AERATION CAN BE AN ISSUE. THE CMC SUPPRESSES THE AIR BUBBLES SO THEY ARE NO LONGER COUNTED AS PARTICLES. IT ALSO ALLOWS FOR CONTINUOUS PARTICLE MONITORING ON SYSTEMS WHERE NO OIL PRESSURE IS EVIDENT.

The CMC can be installed in most low pressure hydraulic and lubrication systems. One option ranging from zero bar pressure to a max of 50 bar on the inlet of the system and 0,5 bar on the return of the system. A further option can be installed on systems with a max of 0,5 bar on inlet of CMC pump and a max of 6 bar on system return. These two options give the user the versatility to install the CMC in a variety of different system applications. Also the Condition Monitoring Center can be designed with an integrated magnetic coupling. This option can handle inlet and outlet pressures of 25 bar. Utilizing the best particle counter in its class as standard, the CMC delivers simplicity, practicality & accuracy for the most demanding of applications. Proven optical technology and algorithms ensure consistent monitoring of your system, providing peace of mind for your operators.

The CMC comes with an optional CMS complete with RS485/232 MODBUS & CANBUS

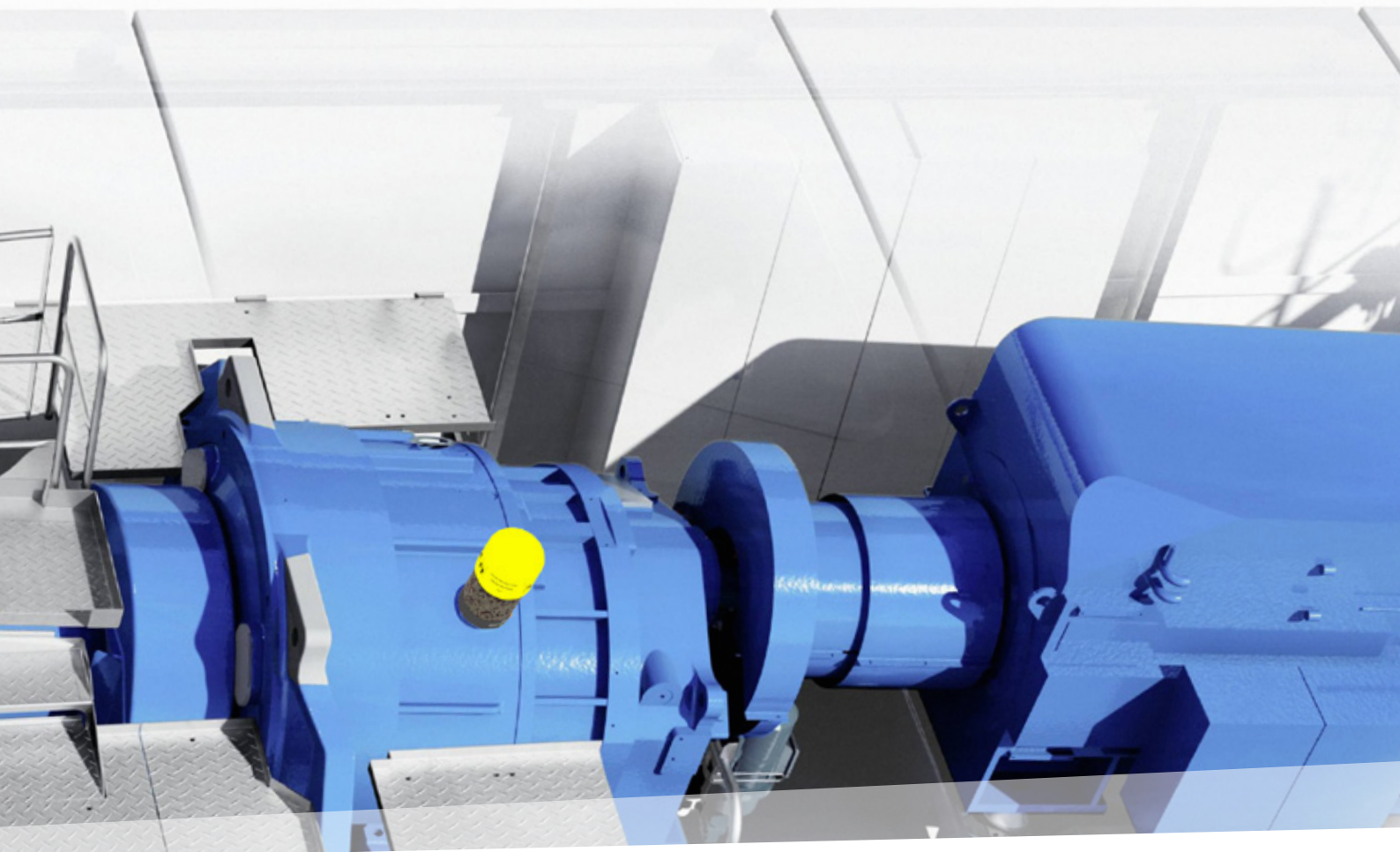

(J1939 typical) protocols for remote control. CMS Communication & motor power needs to be completed by the customer during installation. The cable for motor power is not supplied. Optionally the CMC can be equipped with an Oil Quality Sensor (OQS), used for measuring oil degradation.

#### DESIGNED WITH YOU IN MIND...

The CMC is specifically configured to provide customers the versatility they require for existing systems or those in development. The built-in motor/pump assembly and automatic particle counter (CMS) can be wired to directly, allowing control through a wide range of communication protocols and logic controllers. A small footprint makes it the ideal solution for installation on new or retrofit applications. A wide range of operating voltages allow us to support a global market, and emerging technologies.

The CMC can give you reliable feedback about solid particle contamination levels, water level (%RH), oil degradation and temperature. Making it the most advanced diagnostic centre for hydraulic and lubrication fluids.

#### WHEN SHOULD IT BE USED?

- ▶ Entrained air or turbulent flows
- ▶ Higher viscosity fluids
- ▶ Un-pressurized systems

#### WHY SHOULD IT BE USED?

- ▶ Reliable & accurate performance.
- ▶ Allows for pro active maintenance
- ▶ Certifying test benches
- ▶ Easy to retro-fit.
- ▶ Exceptional communication & 4.000 test memory.
- ▶ Alarms for contamination levels
- ▶ Alarm for water
- ▶ Alarm for temperature

# CMC Specification

## OPERATIONAL PARAMETERS

Fluid Compatibility / Corrosion Resistance	Hydrocarbon based & Synthetic hydraulic fluids
Min Inlet Pressure	positive pressure
Max Inlet pressure	50 bar (pump option dependant)
Max Outlet pressure	6 bar (pump option dependant)
Max. Fluid Temperature (Continuous)	Max. 80 °C viscosity dependant. Not lower than 10 cSt
Min Fluid Temperature (Continuous)	Viscosity dependant. Not greater than 1.000 cSt
Min Temperature (Start Up)	Viscosity dependant. Not greater than 1.000 cSt $\approx$ 25 °C ISO VG 320
Max. Viscosity	1.000 cSt
Min. Viscosity	10 cSt
Min. Start Up Ambient Temperature	-30° C
Max. Continuous Ambient Temperature	65° C
Power Consumption	0.25 kW max
Weight	13 Kg

## CONTAMINATION MONITORING SENSOR

In-line contamination monitor	CMS with keypad and backlit display and relays.
Particle Sizing & Channels	As CMS: >4, 6, 14, 21, 25, 38, 50, 70 $\mu$ m(c) to ISO 4406 1999 Standard
Moisture Sensing (RH%)	Available with or without moisture sensor
Communication Protocols	PLC compatible. RS485, RS232 & CanBus (J1939 typical)
Software	RMF View (Supplied with product)
Re-calibration	Defined by customer Quality Controls
On/off & Stop/Start signals (Remote)	Start/Stop signalling & test set up user defined.
Hydraulic Hoses (External)	Customer to source their own
Circuit Flow Rate	40 ml/min to 400 ml/min (viscosity dependant)
Electric Motor	110VAC, 230VAC, 400VAC, 690VAC
USBi Comms Junction Box	Optional , order with CMS

## OIL QUALITY SENSOR

Material	Stainless Steel AISI304
Analogue output	4 - 20 mA
Digital output	1xRS485: 9600 baud half duplex, Modbus protocol supported on RS485 CANbus: CANopen protocol supported on RS485
Dimensions	90 mm x 37 mm
Power supply	9 - 30VDC
Protection class	IP67
Weight	160 g
Output connection	6 PIN Lumberg
Mechanical connection	1/2" BSP Thread
Seals	FPM

## OIL QUALITY DISPLAY

Material	Polycarbonate
Protection class	IP67 (when connected)
Analogue output	4 - 20 mA
Digital output	RMF Systems protocol
Dimensions (LxWxH)	120 mm x 66 mm x 42 mm
Weight	225 g
Mounting	Integrated flanges
Power	9 - 30 VDC
Average power consumption	0.4 W
Power consumption	30 mA continuous
Analog output	4-20 mA
Display	Oil Quality
	Oil Temperature
	Rate of Change
	Status indicator

## Main Dimensions

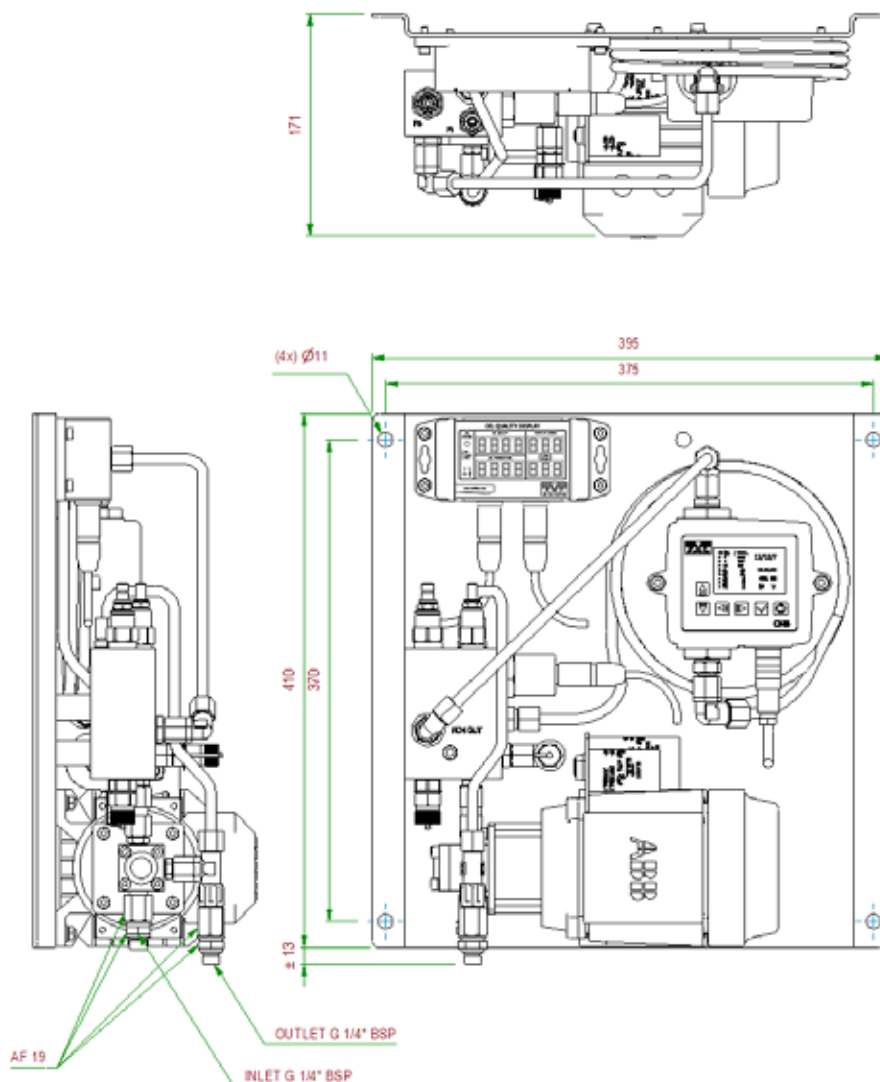

Figure 1: Main dimensions

# Hydraulic Diagram

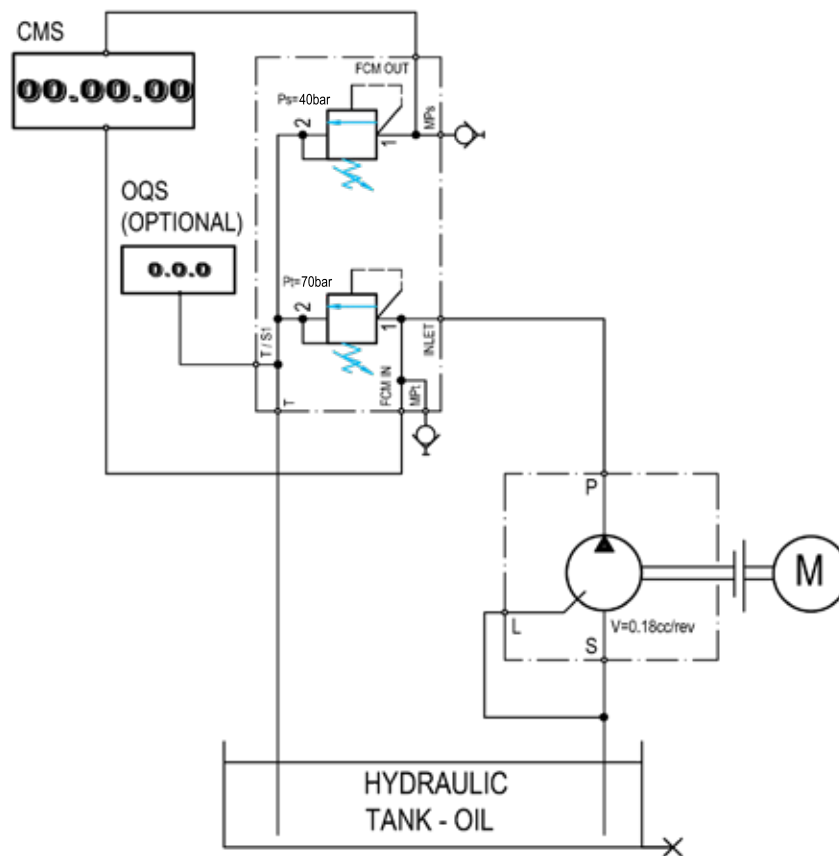

Figure 2: Diagram CMC without drain

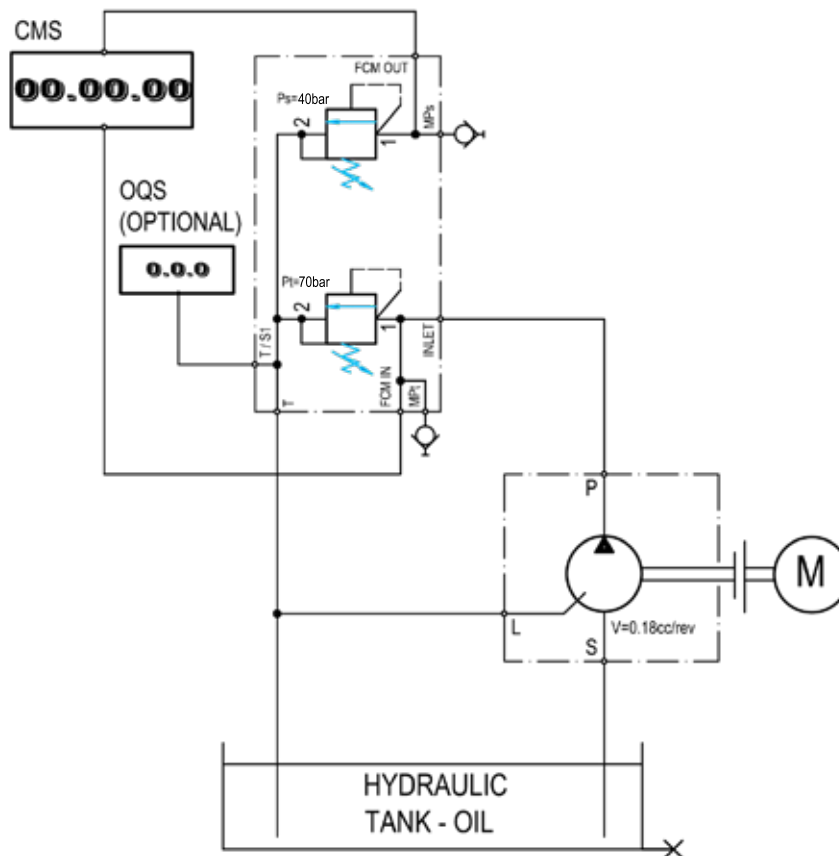

Figure 3: Diagram CMC with drain

# Contamination Monitoring Sensor CMS

The CMS in-line contamination monitor automatically measures and displays particulate contamination, moisture and temperature levels in various hydraulic fluids. It is designed specifically to be mounted directly to systems where ongoing measurement or analysis is required, and where space and costs are limited.

## CMS WATER EN TEMPERATURE SENSOR

The water sensor option measures water content using a capacitive RH (relative humidity) sensor. The results is expressed as percentage saturation.

100% RH corresponds to the point at which free water exists in the fluid, i.e. the fluid is no longer able to hold the water in a dissolved solution.

## SOFTWARE

All CMS Units are supplied with software that can be installed on you PC. The results can be downloaded from the CMS to your computer. When the CMS is connected to the PC, it can be controlled directly by the software.

Alternatively historical results can be downloaded form the CMS's in built memory. The CMS memory has space for around 4000 log entries, when full, the oldest log entry is overwritten.

- ▶ Which test are logged, and when, are determined by the log settings
- ▶ Each log entry is time-stamped and contains the CMS serial number, so that it can be identified later.

## CMS ALARM RELAY STATUS LED

All CMS versions have a multicoloured indicator on the front panel, which is used to indicate the status or alarm state. The alarm thresholds can be set from the supplied software via the serial interfaces.

## SPECIFICATION

LED Based Light Extinction  
Automatic Optical Particle  
Counter

### Analysis Range

ISO 4406:1999 code 0 to 25  
NAS 1638 Class 00 to 12  
AS4059 Rev.E. Table 2  
Sizes A-F: 000 to 12  
(lower Limits Test Time  
dependent)

### Measurement in 8 channels with particle sizing

4,6,14,21,25,38,50,70  $\mu\text{m(c)}$   
to revised ISO 4406 Standard



## CMS "USB-I" CONNECTOR

This is a ready-made solution for easily connecting a PC/ Laptop to the CMS. It comprises of a USB:RS485 interface with a terminal block pre-wired to connect directly to the CMS. An extra terminal block is provided for any customer wanting to wire external devices through two solid state relays. An external DC adapter can be used to power the complete system, or if the computer is always connected during use, power can be taken directly from the USB cable. Powered PC / Laptops only.

# Oil Quality Sensor

## OQS

The Oil Quality sensor (OQS) from RMF Systems puts you in control with real-time monitoring of oil degradation due to contamination and water ingress. Expensive oil changes are now based on oil condition, not on historical schedule.

### ENVIRONMENTAL

Strict schedule based maintenance programmes have several downsides. Environmental experts argue that the greatest of these is the preventable waste. The Oil Quality Sensor (OQS) real-time monitoring sensor makes extending the oil service life effortless.

### MARKET LEADING

The Oil Quality Sensor (OQS) is 60 times more sensitive to oil degradation than any other dielectric constant measuring sensor.

### INTELLIGENT

The OQS measures the energy loss component of oil permittivity. All contaminants such as metallic particles, soot, water, oxidization, glycol and particularly burnt fuel dilution increase this measured value.



### UNIVERSAL

Reliably measures oil degradation in all industrial equipments, including;

- ▶ Diesel and petrol engines
- ▶ Compressors
- ▶ Industrial gear reducers
- ▶ Wind turbines
- ▶ Generator sets
- ▶ Hydraulic systems

### BENEFITS

- ▶ Reduced maintenance cost
- ▶ Extended oil change intervals
- ▶ Scheduled downtime intervals for increased productivity
- ▶ Reduced waste oil cost
- ▶ Improved equipment reliability
- ▶ Low cost investment tool
- ▶ Reduced carbon foot print
- ▶ Reduces total cost of ownership

### OQS FACTS

- ▶ Robust design
- ▶ Resistant to high fluid temperatures, -40 C °to 120 C °
- ▶ Resistant to fluid pressures up to 20 bar

### OIL QUALITY DISPLAY

The Oil Quality Display is a simple but powerful device which allows you to read the quality and temperature of the oil from a sensor without a PC.

This enables you to set up the display box on site and then be able to see the oil quality and temperature readings as required. Use an Android app to connect your Smartphone with the OQD smart via Bluetooth. With it being IP67 rated (when connected) you do not need to worry about the need to keep it in a dry place. Also with it being made from polycarbonate it is a strong durable product which cannot be damaged easily. The new 'Rate of Change' feature allows you to easily monitor the degradation of oil over a programmable period of time.





# Ordering code

## CONDITION MONITORING CENTER

YOUR CMC ORDERING CODE							
TABLE 1	TABLE 2	TABLE 3	TABLE 4	TABLE 5	TABLE 6	TABLE 7	TABLE 8
CMC							

TABLE 1 - BASIC CONFIGURATION	CODE
Condition Monitoring Center	CMC

TABLE 2 - MOUNTING OPTIONS	CODE
Plate mounted	1
Cabinet mounted (with a transparent door)	2

TABLE 3 - WORKING PRESSURES	CODE	
MAIN SAFETY	WORKING PRESSURES	
70 bar	40 bar (standard)	AA

TABLE 4 - PUMP CONFIGURATION	CODE
Pressure on inlet, up to 50 bar inlet, atmosphere outlet (standard)	1
Pressure on outlet, 0 - 0,5 bar max. inlet, 6 bar max. outlet	2
Pressure on inlet and outlet with separate drain, up to 50 bar inlet, 6 bar max outlet, atmosphere drain (0 - 0,5 bar max.)	3

TABLE 5 - E-MOTOR OPTIONS	CODE
230/400 VAC 50Hz / 3 Phase	0
255/460 VAC 60Hz / 3 Phase	
230 VAC 50Hz / 1 Phase	A
110 VAC 60 Hz / 1 phase	D
690 VAC 50Hz / 3 Phase	H
200/346 VAC 50/60Hz / 3 Phase	P

TABLE 6 - THREADED CONNECTION OPTIONS	CODE
1/4" BSP male thread (standard)	1
1/4 " BSP female thread	2
7/16 " UNF male thread	3

TABLE 7 - SMART OPTIONS (FOR DETAILS, SEE ORDERING CODES CMS OR OQS)	CODE
No options	1
RMF full option (standard) CMS installed	2
RMF OQS/OQD installed	3
RMF OQS/OQD and full option (standard) CMS installed	4
RMF CMS-0-M-K-R-G1	5
RMF CMS-W-M-0-R-G1	6
RMF CMS-0-M-0-R-G1	7
RMF OQS/OQD and CMS-0-M-0-R-G1	8
RMF OQS/OQD and CMS-W-M-0-R-G1	9
RMF OQS/OQD and CMS-0-M-K-R-G1	0

TABLE 8 - ELECTRICAL OPTIONS	CODE
No options (standard)	1
Control box	3

## OIL QUALITY SENSOR

YOUR OQS ORDERING CODE					
TABLE 1	TABLE 2	TABLE 3	TABLE 4	TABLE 5	TABLE 6
OQS	1	08	0	SC	4

TABLE 1 - BASIC CONFIGURATION	CODE
Oil Quality Sensor	OQS

TABLE 2 - MATERIAL CASE	CODE
Stainless steel (standard)	1

TABLE 3 - THREADED CONNECTION OPTIONS	CODE
G1/2" BSP male thread	08
Alternative connections on special request	

TABLE 4 - SEALING OPTIONS	CODE
DIN 3852-11 Form E / ISO 1179-2 Viton (standard)	0

TABLE 5 - OUTPUT CONNECTION OPTIONS	CODE
Straight circular connector	SC
Lumberg M16x0,75 (6-pin IP67) (standard)	
Note: the connector is not included in the supply	

TABLE 6 - COMMUNICATIONS OPTIONS	CODE
Smart version - Protocol for RS485 2w / Modbus / Canbus / 4 - 20 mA	4

ACCESSORIES (ORDER SEPARATELY)	CODE
Display with data logger	OQD-S-1
USB communication cable with external power supply	OQS CONFIGURATION KIT
OQS to OQD cable	OQC-02-1
OQS/OQD to bare ends cable	OQC-02-2

# Details

## CONTAMINATION MONITORING SENSOR

YOUR CMS ORDERING CODE						
TABLE 1	TABLE 2	TABLE 3	TABLE 4	TABLE 5	TABLE 6	TABLE 7
CMS				R		

TABLE 1 - BASIC CONFIGURATION	CODE
Contamination Monitoring Sensor	CMS

TABLE 2 - SENSOR OPTIONS	CODE
Moisture sensor option (mineral oil only)	W
No sensor option	0

TABLE 3 - FLUID COMPATIBILITY	CODE
Mineral fluid compatibility	M
<b>WITH ANODISED OUTER CASE (NOT AVAILABLE WITH WATER SENSOR)</b>	
Offshore and selected water based fluids	N
Phosphate ester and aggressive fluids	S

TABLE 4 - KEYBOARD AND DISPLAY	CODE
6 key keypad and 128 x 64 pixel back lit graphical display	K
No keypad and display	0

TABLE 5 - RELAYS	CODE
Two fully customisable "alarm" relay outputs to set upper and lower limits for the test results and indicates these via a "multicolour" front panel LED indicator and/or remote devices.	R

TABLE 6 - PORT OPTIONS	CODE
Test point M16 x 2 (standard)	G1
1/8" BSP	G2
1/4" BSP	G3

TABLE 7 - EXTRA OPTIONS	CODE
Flow control valve assembled	FC1
ATEX ZONE II CE II 3 G Ex nR IIB T6 X	AZ2

RELATED PRODUCTS - TO BE ORDERED SEPERATELY	CODE
CMS remote display unit with keypad (same port size as CMS unit)	CMS-RDU
CMS to PC USB connector unit	CMS-USBi

### WARRANTY AND RECALIBRATION

The CMS is guaranteed for 12 months from date of receipt and is recommended to be recalibrated every 12 months. Return to RMF Systems for recalibration.



## We're Here To Help You

Coenecoop 71 | 2741 PH

Waddinxveen | The Netherlands

T: (31) 182 30 28 88

E: [info@rmffilter.com](mailto:info@rmffilter.com)



Your Local Distributor



SUBJECT TO CHANGE WITHOUT PRIOR NOTICE

Copyright ©24 November 2016, 11:27 RMF Systems

All rights reserved. No part of this publication may be reproduced or extracted in any form or by any means without the prior written permission of the publisher.

B\_CMC\_20160229\_EN