

RMF SYSTEMS



www.bsf-filtrertechnik.com

Off-line Units
OLU, OLUW, OLUH, OLUS



OLU*A & OLU*B

EXTREME FILTER EFFICIENCY

THE RMF OFF-LINE UNITS ATTACK CONTAMINATION OF YOUR SYSTEM AT THE SOURCE. IN ADDITION TO SOLID PARTICLES, THESE FILTERS ARE ALSO CAPABLE OF REMOVING WATER FROM THE OIL. THE USE OF RMF FILTERS MEANS LESS DEFECTS, LESS MAINTENANCE, AND LESS WEAR AND TEAR OF THE HYDRAULIC COMPONENTS. THE RMF OFF-LINE UNITS CAN BE FITTED TO EVERY IMAGINABLE INDUSTRIAL APPLICATION WHERE HYDRAULIC OR LUBRICATION SYSTEMS ARE PRESENT.

The RMF Systems radial micro filter units are characterized by their extremely efficient filter elements with a fineness of down to 0,5 micron. If required, different micron sizes are available to suit any application.

The RMF Off-Line Units are specially designed for industrial hydraulic installations.

The Off-Line Units are available in single or multiple housing configurations.

OPERATION

The Off-Line Units can be easily mounted to new and existing hydraulic installations. By means of an integrated pump-motor unit in the Off-Line Units, the oil is pumped from the reservoir through the filter unit. After

filtering the oil is returned to the tank.

Off-Line Units can continue to work even when the main system is not in use. Element change can also be done without interfering with the main system.

YOUR BENEFITS

The hydraulic market accepts that 80% of mechanical failures are caused by contamination in the system.

The RMF Off-Line Units attack this contamination at source and are also capable of removing water from the oil. This prevents the catalytic reaction of water and solid particle contamination, resulting in extended usable oil life.

THE BENEFITS OF RMF FILTERS

- ▶ Reduced cost of ownership
- ▶ Extremely clean oil due to high filtration efficiency
- ▶ Prevention of channel forming by radial filtration direction
- ▶ Large dirt holding capacity
- ▶ Large water holding capacity
- ▶ Compact and easy maintenance design
- ▶ Longer usage life for oil and components

APPLICATION

- ▶ Steel industry
- ▶ Plastic injection moulding
- ▶ Power generation
- ▶ Marine Industry
- ▶ Pulp & Paper Industry
- ▶ Cement Industry
- ▶ Flight Simulators

Specification OLU1



PRODUCT DETAILS		
	OLU1A	OLU1B
Nominal Flow	2,1 l/min	4,2 l/min
Standard Max. Oil Temperature ¹	80°C	
Max. pressure filter housing	20 bar	
Inlet connection ²	3/8" BSP female	1/2" BSP female
Outlet connection	1/2" BSP female	
Power supply Electric Motor	Various electrical power supplies possible (see ordering code)	
Suitable elements ³	30HB, 30HV, 30NB, 30NV, 30G1B, 30G1V, 30G3B, 30G3V, 30A5B	30HB, 30HV, 30NB, 30NV, 60HB 60HV, 60NB, 60NV, 30G1B, 30G1V, 30G3B, 30G3V, 30A5B, 60G1B, 60G1V, 60G3B, 60G3V
By-pass openings pressure	6,2 bar (at 0 bar back pressure)	
Pump safety valve	15 bar	
Max. Tank volume	±1,350 l	± 2,700 l
Fluid Compatibility ⁴	Hydraulic fluids according ISO 2943	
Approximate weight	14 kg	18 kg

¹For other oil temperatures please contact RMF Systems

²Inlet Connections are pump dependent. Please contact RMF Systems or your distributor.

³For complete specifications of the RMF Systems Filter elements see page 41

⁴For other fluids, please contact RMF Systems

Dimensions OLU1

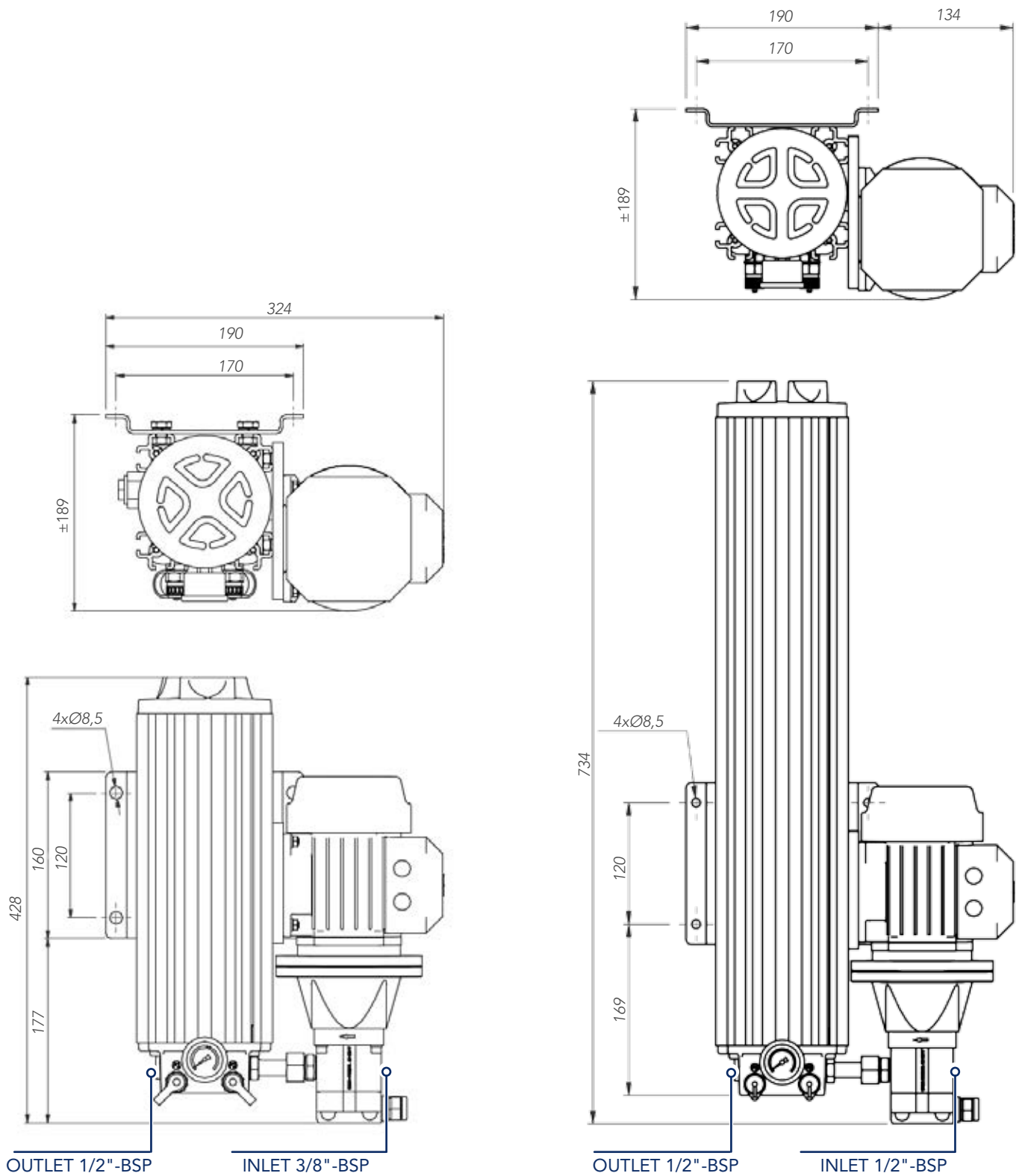

Specification OLU2



PRODUCT DETAILS		
	OLU2A	OLU2B
Nominal Flow	4,2 l/min	8,4 l/min
Standard Max. Oil Temperature ¹	80°C	
Max. pressure filter housing	20 bar	
Inlet connection ²	½" BSP female	½" BSP female
Outlet connection	½" BSP female	
Power supply Electric Motor	Various electrical power supplies possible (see ordering code)	
Suitable elements ³	30HB, 30HV, 30NB, 30NV, 30G1B, 30G1V, 30G3B, 30G3V, 30A5B	30HB, 30HV, 30NB, 30NV, 60HB 60HV, 60NB, 60NV, 30G1B, 30G1V, 30G3B, 30G3V, 30A5B, 60G1B, 60G1V, 60G3B, 60G3V
By-pass openings pressure	6,2 bar (at 0 bar back pressure)	
Pump safety valve	15 bar	
Max. Tank volume	± 2,700 l	± 5,400 l
Fluid Compatibility ⁴	Hydraulic fluids according ISO 2943	
Approximate weight	21 kg	30 kg

¹For other oil temperatures please contact RMF Systems

²Inlet Connections are pump dependent. Please contact RMF Systems or your distributor.

³For complete specifications of the RMF Systems Filter elements see page 41

⁴For other fluids, please contact RMF Systems

Dimensions OLU2

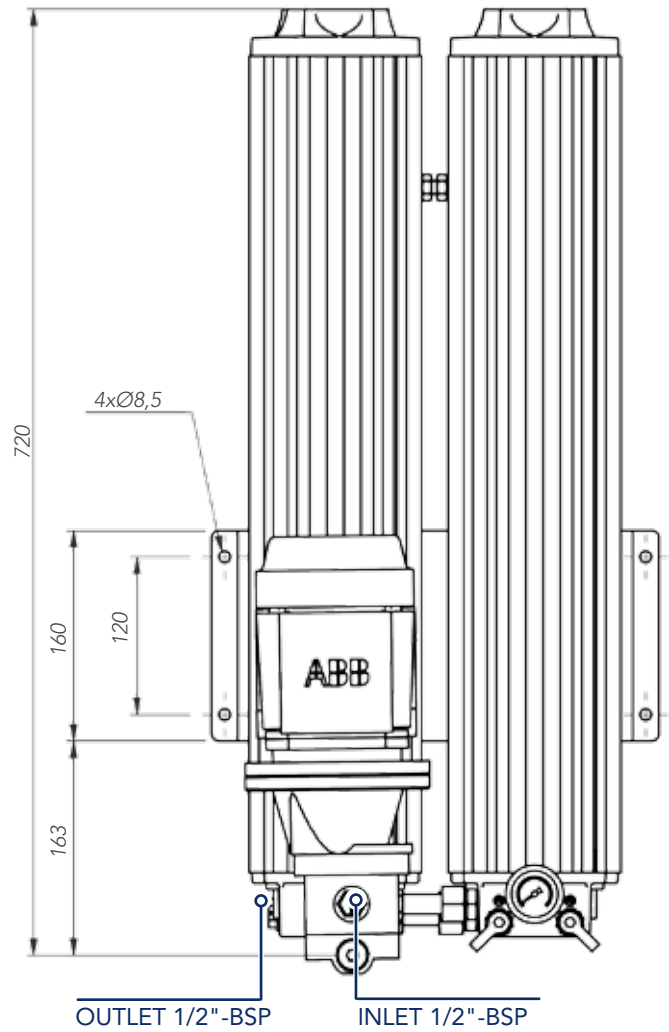
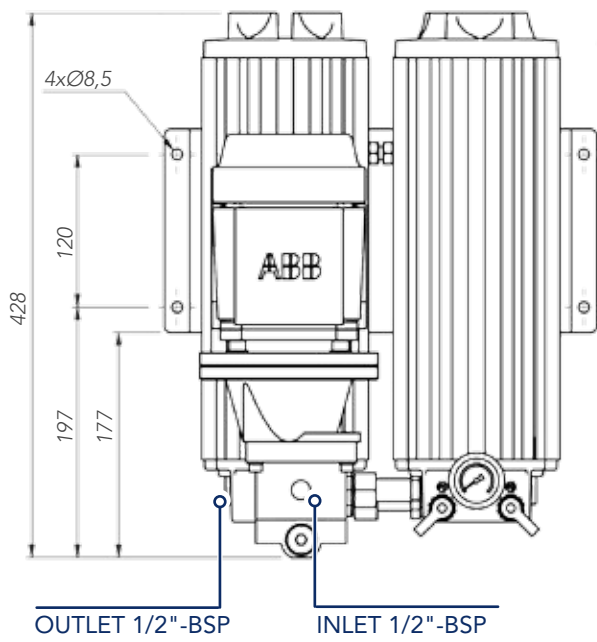
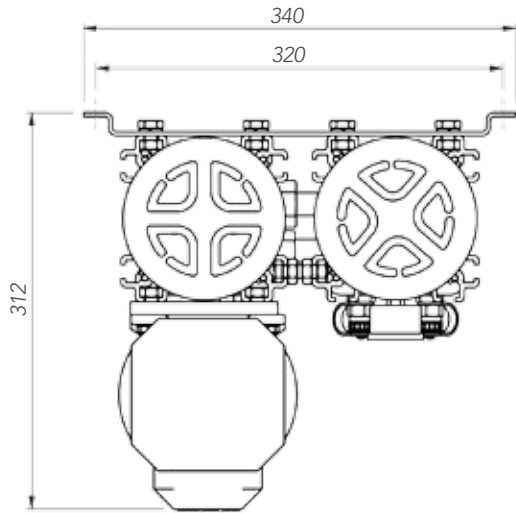

Specification OLU4



PRODUCT DETAILS

	OLU4A	OLU4B
Nominal Flow	8.4 l/min	16,3 l/min
Standard Max. Oil Temperature ¹	80° C	
Max. pressure filter housing	20 bar	
Inlet connection ²	½" BSP female	¾" BSP female
Outlet connection	EW 22L	
Power supply Electric Motor	Various electrical power supplies possible (see ordering code)	
Suitable elements ³	30HB, 30HV, 30NB, 30NV, 30G1B, 30G1V, 30G3B, 30G3V, 30A5B	30HB, 30HV, 30NB, 30NV, 60HB 60HV, 60NB, 60NV, 30G1B, 30G1V, 30G3B, 30G3V, 30A5B, 60G1B, 60G1V, 60G3B, 60G3V
By-pass openings pressure	6,2 bar (at 0 bar back pressure)	
Pump safety valve	15 bar	
Max. Tank volume	± 5,400 l	± 10,800 l
Fluid Compatibility ⁴	Hydraulic fluids according ISO 2943	
Approximate weight	39 kg	61 kg

¹For other oil temperatures please contact RMF Systems

²Inlet Connections are pump dependent. Please contact RMF Systems or your distributor.

³For complete specifications of the RMF Systems Filter elements see page 41

⁴For other fluids, please contact RMF Systems

Dimensions OLU4

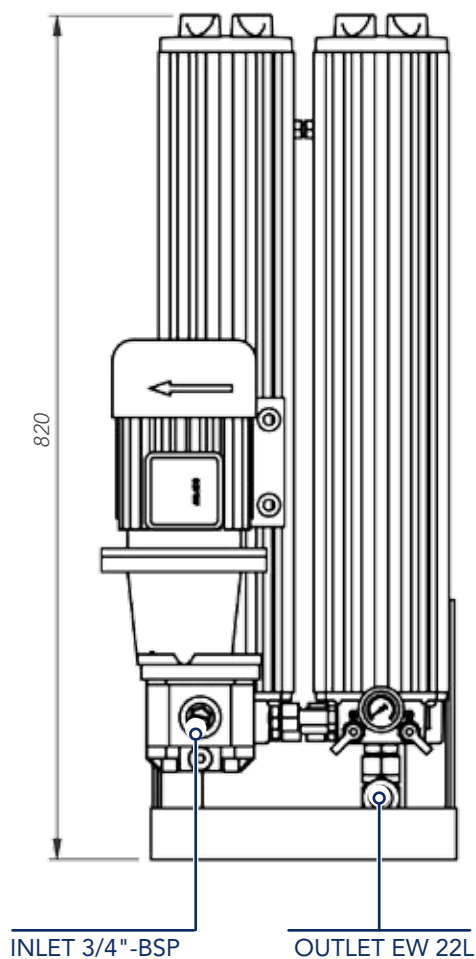
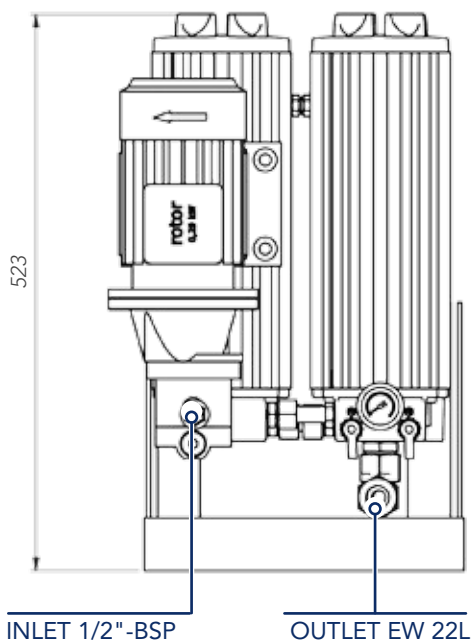
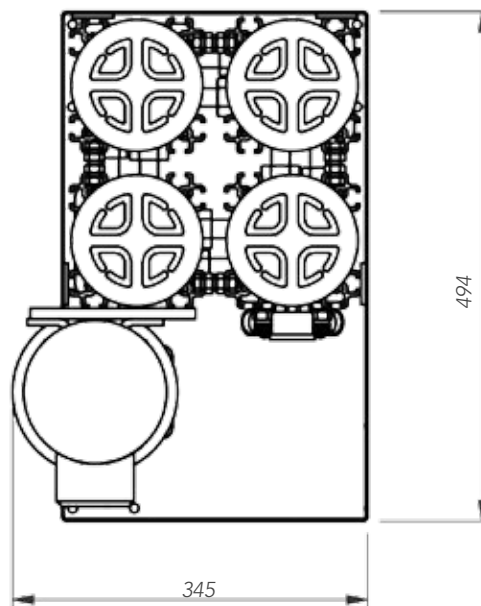
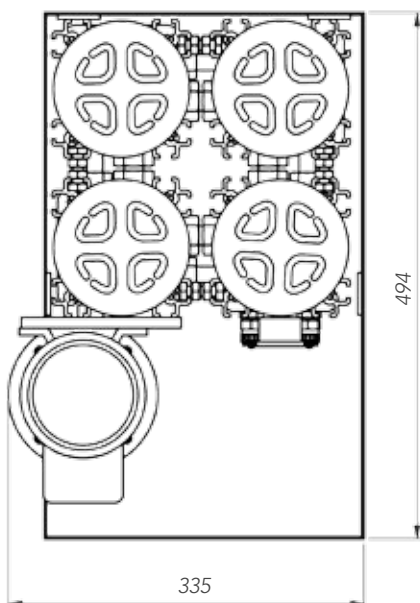

Ordering Code

OLU A & B

YOUR OFF-LINE FILTER ORDERING CODE

TABLE 1	TABLE 2	TABLE 3	TABLE 4	TABLE 5	TABLE 6	TABLE 7	TABLE 8	TABLE 9	TABLE 10
OLU									

TABLE 1 - BASIC CONFIGURATION

		CODE
Off-line unit	Industrial applications	OLU

TABLE 2 - HOUSING CONFIGURATION

HOUSING CONFIGURATION	TYPICAL RESERVOIR SIZE	CODE
Single housing (single length)	Suitable for 1350 l reservoir	1A
Twin housing (single length)	Suitable for 2700 l reservoir	2A
Quadruple housing (single length)	Suitable for 5400 l reservoir	4A
Single housing (double length)	Suitable for 2700 l reservoir	1B
Twin housing (double length)	Suitable for 5400 l reservoir	2B
Quadruple housing (double length)	Suitable for 10800 l reservoir	4B

TABLE 3 - LENGTH ELEMENT

	CODE
300 mm	30
600 mm	60

TABLE 4 - FILTER MATERIAL

	CODE
Cellulose 0.5 micron, bottom seal	H
Cellulose 0.5 micron, NO bottom seal	N
Glass fiber with polymer, 5 micron, $\beta_5 \geq 200$	A5
Glass fiber, 1 micron $\beta_1 \geq 200$	G1
Glass fiber, 3 micron $\beta_3 \geq 200$	G3
Cellulose 0.5 micron, for Motor oil *	X

* Only suitable in combination with Viton seal

SUITABLE FOR WATER GLYCOL

Glass fiber, 1 micron $\beta_1 \geq 200$	W1
Glass fiber, 3 micron $\beta_3 \geq 200$	W3

TABLE 5 - SEAL MATERIAL

	CODE
Buna-N (standard)	B
Viton	V

TABLE 6 - E-MOTOR OPTIONS

	CODE
230 / 400 VAC 50 Hz / 3 phase (standard)	0
255 / 460 VAC 60 Hz / 3 phase	
230 VAC 50 Hz / 1 phase	A
24 VDC	B
110 VAC 50 Hz / 1 phase	C
110 VAC 60 Hz / 1 phase	D
230 / 400 VAC 50 Hz, IP65 / 3 phase	E
230 VAC 60 Hz / 1 phase	F
690 VAC 50 Hz / 3 phase	H
500 VAC 50 Hz / 3 phase	N
575 VAC 60 Hz / 3 phase	M
200 / 346 VAC 50/60 Hz / 3 phase	P
Special motor, on request	S
Explosion proof, on request	X

TABLE 7 - PUMP OPTIONS		CODE
STANDARD FOR 50 HZ MOTOR		
1.6 cc/rev. group 1	OLU1A	00
3.2 cc/rev. group 1	OLU2A / OLU1B	10
5.8 cc/rev. group 1 (standard)	OLU4A / OLU2B	20
8.0 cc/rev. group 2		30
12.0 cc/rev. group 2	OLU4B	40
0.8 cc/rev. group 1	Obsolete	50
1.1 cc/rev. group 1		60
STANDARD FOR 60 HZ MOTOR		
1.1 cc/rev. group 1	OLU1A	01
2.7 cc/rev. group 1	OLU2A / OLU1B	11
4.8 cc/rev. group 1	OLU4A / OLU2B	21
10 cc/rev. group 2	OLU4B	41
OTHER PUMPS		
Special pumps		S

TABLE 8 - INDICATOR		CODE
Pressure gauge (standard)		0
Additional electr. switch		1
Additional Δp switch		2
Electr. switch only		3
OQS		4
OQS + display		5
OQS prepared		6
CMS prepared		7

TABLE 9 - EXTRA OPTIONS		CODE
No options		0
Motor / pump right side mount		1
Motor / pump left side mount		2
Motor / pump front side mount		3
Controlbox Incl. on/off and motor protection relais		4
Incl. motor protection / start stop / by-pass ext.		5
Stainless steel components		S
Controlbox incl. On/off motor + protection relais and 24 VDC		6

TABLE 10 - DRIPTRAY OPTION		CODE
No Drip tray		0
Drip tray		D



OLUW*A & OLUW*B

OFF-LINE FILTER UNIT WITH H₂O SORB

RMF systems radial micro filter units are characterised by their extremely efficient filter elements with a fineness of 0.5 micron. If required different micron sizes are available to suit any specific application. The off-line filters can be equipped with special water absorbing pre-filters in case of extreme water contamination, these water absorbing spin-on cans will remove most of the water prior to the fluid reaching the cellulose element.

Specially designed for industrial hydraulic installations the RMF Off-line filters are available in single or multiple housing configurations. The off-line filter units can be easily mounted to new and existing hydraulic installations. By means of an integrated pump-motor unit in the off-line filter, the oil is pumped from the reservoir through the filter unit and after filtering the oil is then returned to the tank.

ECONOMICAL

The hydraulic market accepts that 80% of mechanical failures are caused by contamination in the system.

The RMF Water Absorbing Off-line filters attack this contamination at source and in addition to solid particles, these filters are also capable of removing water from the oil. This prevents the catalytic reaction of water and solid particle contamination, resulting in extended usable oil life. The use of RMF filters means less defects, less maintenance, and less wear and tear of the hydraulic components.

WATER ABSORBING

RMF Water absorbing filters are off-line filters that use a special water absorbing spin-on as a pre-filter. The fluid is pumped through the pre-filter which removes most water and larger solid contamination, in the second stage the fluid passes through the RMF cellulose micro filter where final water removal takes place as well as solid particle removal.

APPLICATIONS

RMF Water absorbing Off-line filter units can be fitted to every imaginable industrial application where hydraulic and/or lubrication systems are present.

The standard range of Off-line filters can be utilised in reservoirs with a maximum volume of 11.000 litres. A large selection in electrical motors is available ranging from single phase, three phase to explosion proof. In recent years RMF Systems have developed a great deal of experience in cleaning and keeping clean hydraulic and lubrication systems in:

- ▶ Steel industry;
- ▶ Plastic moulding industry;
- ▶ Maritime industry;
- ▶ Petro chemical industry;
- ▶ Paper industry.

ADVANTAGES

- ▶ Extremely clean oil due to high filtration efficiency
- ▶ Prevention of channel forming by radial filtration direction
- ▶ Increased flow capacity
- ▶ Large dirt holding capacity
- ▶ Large water holding capacity
- ▶ Compact and easy-maintenance design
- ▶ Environmentally friendly elements available
- ▶ Longer usage life for oil and components
- ▶ Reduces cost of ownership

Specification OLUW1



PRODUCT DETAILS		
	OLUW1A	OLUW1B
Nominal Flow	2,1 l/min	4,2 l/min
Standard Max. Oil Temperature ¹	80°C	
Max. pressure filter housing	20 bar	
Inlet connection ³	3/8" BSP female	1/2" BSP female
Outlet connection	1/2" BSP female	
Power supply Electric Motor	Various electrical power supplies possible (see ordering code)	
Suitable elements ³	30HB, 30HV, 30NB, 30NV, 30G1B, 30G1V, 30G3B, 30G3V, 30A5B	30HB, 30HV, 30NB, 30NV, 60HB 60HV, 60NB, 60NV, 30G1B, 30G1V, 30G3B, 30G3V, 30A5B, 60G1B, 60G1V, 60G3B, 60G3V
Max. Water Absorption capacity	850 ml (with 30A5 element)	1,2 l (with 60a5 element)
By-pass openings pressure	6,2 bar (at 0 bar back pressure)	
Pump safety valve	15 bar	
Max. Tank volume	±1,350 l	± 2,700 l
Fluid Compatibility ⁴	Hydraulic fluids according ISO 2943	
Approximate weight	18 kg	22 kg

¹For other oil temperatures please contact RMF Systems

²Inlet Connections are pump dependent. Please contact RMF Systems or your distributor.

³For complete specifications of the RMF Systems Filter elements see page 41

⁴For other fluids, please contact RMF Systems

Dimensions OLUW1

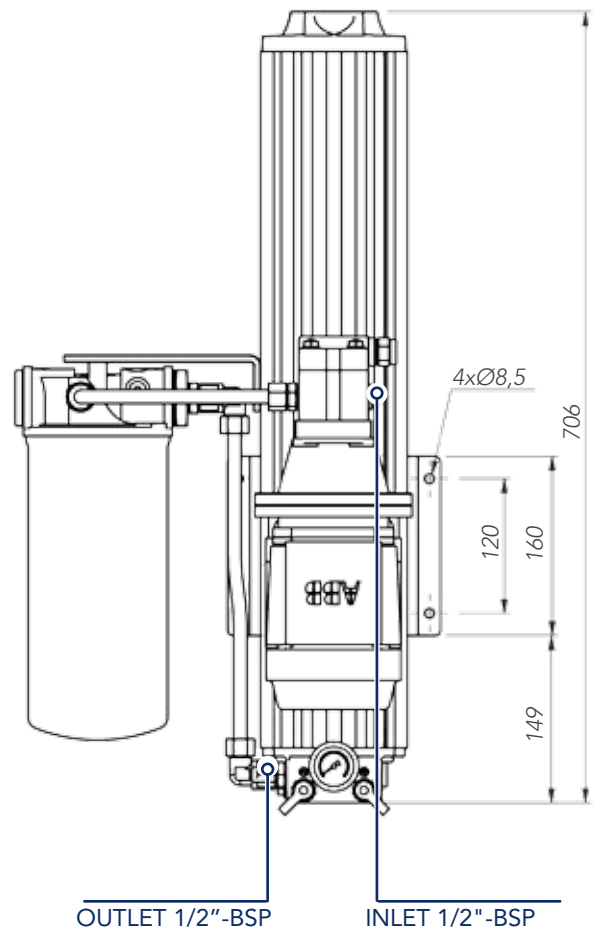
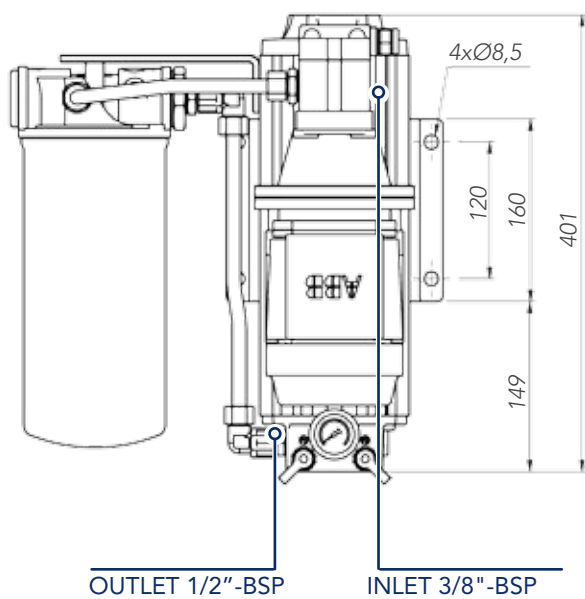
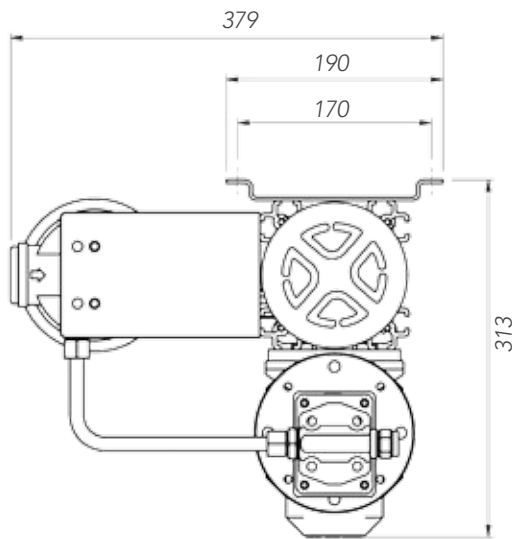

Specification OLUW2



PRODUCT DETAILS		
	OLUW2A	OLUW2B
Nominal Flow	4,2 l/min	8,4 l/min
Standard Max. Oil Temperature ¹	80°C	
Max. pressure filter housing	20 bar	
Inlet connection ²	½" BSP female	½" BSP female
Outlet connection	½" BSP female	
Power supply Electric Motor	Various electrical power supplies possible (see ordering code)	
Suitable elements ³	30HB, 30HV, 30NB, 30NV, 30G1B, 30G1V, 30G3B, 30G3V, 30A5B	30HB, 30HV, 30NB, 30NV, 60HB 60HV, 60NB, 60NV, 30G1B, 30G1V, 30G3B, 30G3V, 30A5B, 60G1B, 60G1V, 60G3B, 60G3V
Max. Water Absorption capacity	1,2 l (with 30A5 element)	1,9 l (with 60A5 element)
By-pass openings pressure	6,2 bar (at 0 bar back pressure)	
Pump safety valve	15 bar	
Max. Tank volume	± 2,700 l	± 5,400 l
Fluid Compatibility ⁴	Hydraulic fluids according ISO 2943	
Approximate weight	25 kg	34 kg

¹For other oil temperatures please contact RMF Systems

²Inlet Connections are pump dependent. Please contact RMF Systems or your distributor.

³For complete specifications of the RMF Systems Filter elements see page 41

⁴For other fluids, please contact RMF Systems

Dimensions OLUW2

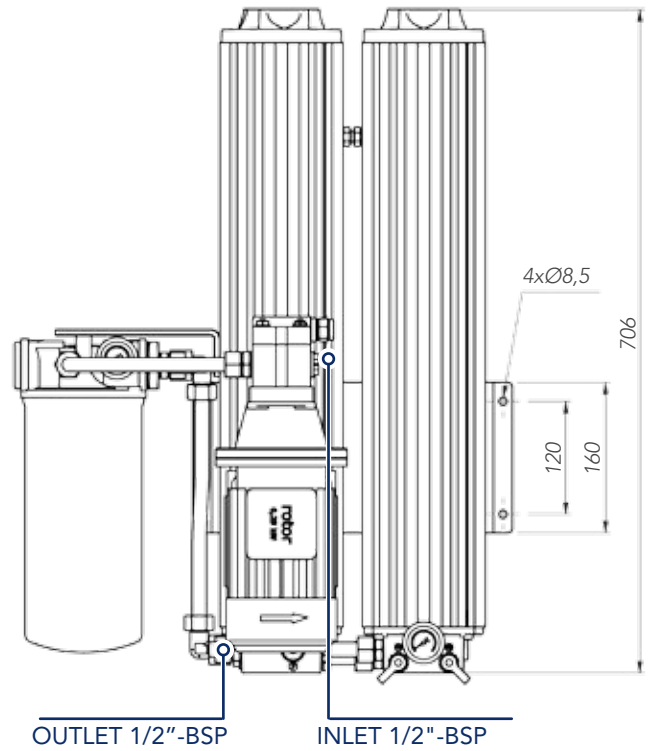
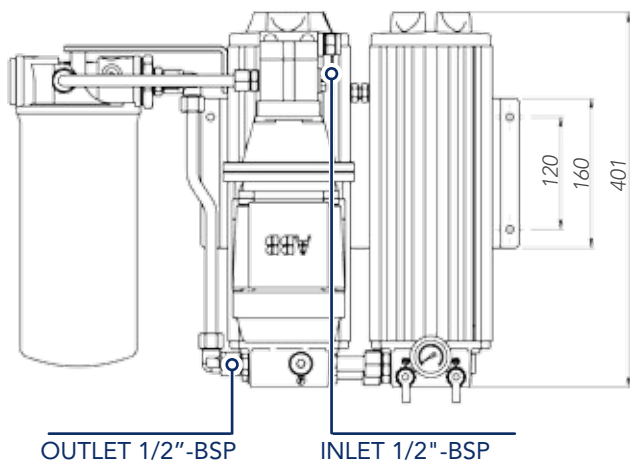
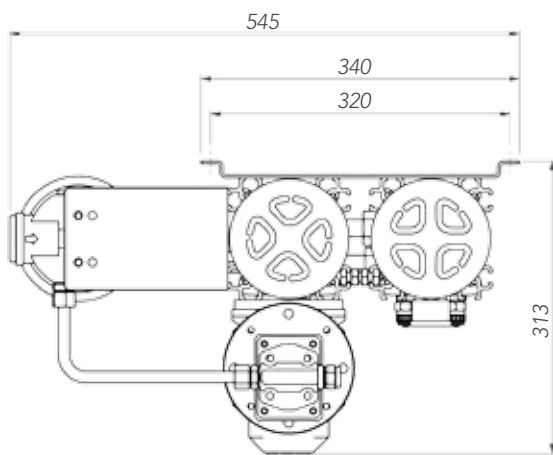

Specification OLUW4



PRODUCT DETAILS		
	OLUW4A	OLUW4B
Nominal Flow	8,4 l/min	16,8 l/min
Standard Max. Oil Temperature ¹	80°C	
Max. pressure filter housing	20 bar	
Inlet connection ²	½" BSP female	¾" BSP female
Outlet connection	22 L	
Power supply Electric Motor	Various electrical power supplies possible (see ordering code)	
Suitable elements ³	30HB, 30HV, 30NB, 30NV, 30G1B, 30G1V, 30G3B, 30G3V, 30A5B	30HB, 30HV, 30NB, 30NV, 60HB 60HV, 60NB, 60NV, 30G1B, 30G1V, 30G3B, 30G3V, 30A5B, 60G1B, 60G1V, 60G3B, 60G3V
Max. Water Absorption capacity	2.4 l (with 30A5 element)	3.8 l (with 60A5 element)
By-pass openings pressure	6,2 bar (at 0 bar back pressure)	
Pump safety valve	15 bar	
Max. Tank volume	± 5,400 l	± 10,800 l
Fluid Compatibility ⁴	Hydraulic fluids according ISO 2943	
Approximate weight	43 kg	65 kg

¹For other oil temperatures please contact RMF Systems

²Inlet Connections are pump dependent. Please contact RMF Systems or your distributor.

³For complete specifications of the RMF Systems Filter elements see page 41

⁴For other fluids, please contact RMF Systems

Dimensions OLUW4

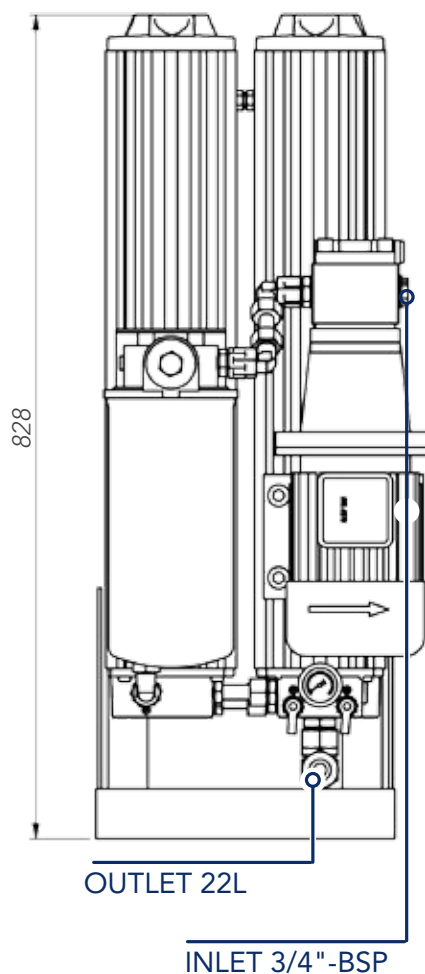
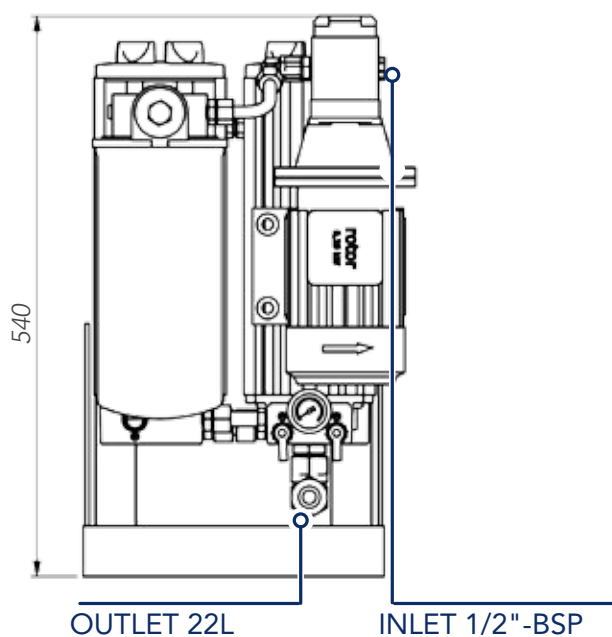
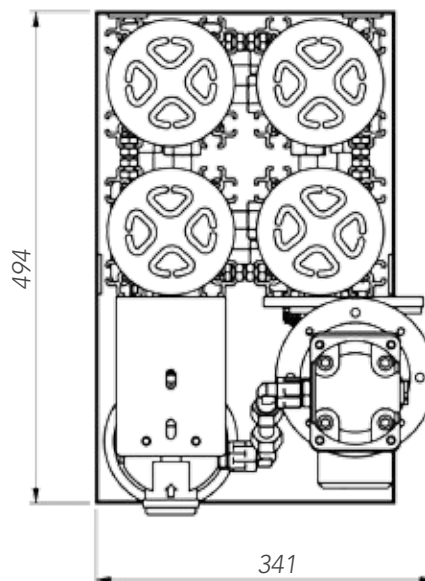
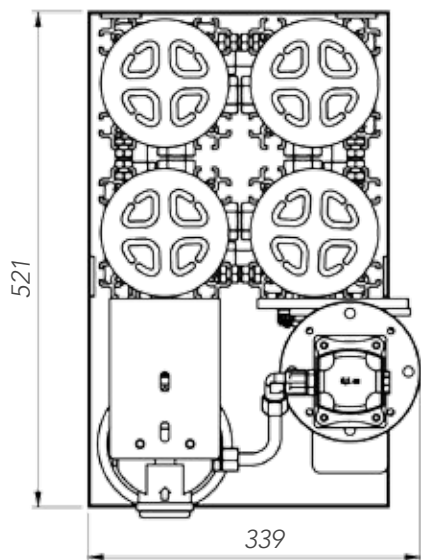

Ordering Code

OLUW A & B

YOUR OFF-LINE FILTER ORDERING CODE

TABLE 1	TABLE 2	TABLE 3	TABLE 4	TABLE 5	TABLE 6	TABLE 7	TABLE 8	TABLE 9	TABLE 10	TABLE 11
OLUW										

TABLE 1 - BASIC CONFIGURATION

TABLE 1 - BASIC CONFIGURATION		CODE
Off-line unit, water absorbing pre-filter	Industrial applications	OLUW

TABLE 2 - HOUSING CONFIGURATION

TABLE 2 - HOUSING CONFIGURATION		CODE
HOUSING CONFIGURATION	TYPICAL RESERVOIR SIZE	
Single housing (single length)	Suitable for 1350 l reservoir	1A
Twin housing (single length)	Suitable for 2700 l reservoir	2A
Quadruple housing (single length)	Suitable for 5400 l reservoir	4A
Single housing (double length)	Suitable for 2700 l reservoir	1B
Twin housing (double length)	Suitable for 5400 l reservoir	2B
Quadruple housing (double length)	Suitable for 10800 l reservoir	4B

TABLE 3 - LENGTH ELEMENT

TABLE 3 - LENGTH ELEMENT	CODE
300 mm	30
600 mm	60

TABLE 4 - FILTER MATERIAL

TABLE 4 - FILTER MATERIAL	CODE
Cellulose 0.5 micron, silicon bottom seal	H
Cellulose 0.5 micron, NO silicon bottom seal	N
Glass fiber with polymer, 5 micron, $\beta_5 \geq 200$	A5
ALSO SUITABLE FOR WATER GLYCOL	
Glass fiber, 1 micron $\beta_1 \geq 200$	G1
Glass fiber, 3 micron $\beta_3 \geq 200$	G3

TABLE 5 - SEAL MATERIAL

TABLE 5 - SEAL MATERIAL	CODE
Buna-N (standard)	B
Viton	V

TABLE 6 - E-MOTOR OPTIONS

TABLE 6 - E-MOTOR OPTIONS	CODE
230 / 400 VAC 50 Hz / 3 phase (standard)	0
255 / 460 VAC 60 Hz / 3 phase	
230 VAC 50 Hz / 1 phase	A
24 VDC	B
110 VAC 50 Hz / 1 phase	C
110 VAC 60 Hz / 1 phase	D
230 / 400 VAC 50 Hz, IP65 / 3 phase	E
230 VAC 60 Hz / 1 phase	F
690 VAC 50 Hz / 3 phase	H
500 VAC 50 Hz / 3 phase	N
575 VAC 60 Hz / 3 phase	M
200 / 346 VAC 50 / 60 Hz / 3 phase	P
Special motor, on request	S
Explosion proof, on request	X

TABLE 7 - PUMP OPTIONS		CODE
STANDARD FOR 50 HZ MOTOR		STANDARD FOR
1.6 cc/rev. group 1	OLU1A	00
3.2 cc/rev. group 1	OLU2A / OLU1B	10
5.8 cc/rev. group 1 (standard)	OLU4A / OLU2B	20
8.0 cc/rev. group 2		30
12.0 cc/rev. group 2	OLU4B	40
0.8 cc/rev. group 1	Obsolete	50
1.1 cc/rev. group 1		60
STANDARD FOR 60 HZ MOTOR		
1.1 cc/rev. group 1	OLU1A	01
2.7 cc/rev. group 1	OLU2A / OLU1B	11
4.8 cc/rev. group 1	OLU4A / OLU2B	21
10 cc/rev. group 2	OLU4B	41

TABLE 8 - INDICATOR		CODE
Pressure gauge (standard)		0
Additional electr. switch		1
Additional Δp switch		2

TABLE 9 - EXTRA OPTIONS		CODE
No options		0
Motor / pump right side mount		1
RMF magnet filter		7

TABLE 10 - WATER ABSORPTION ELEMENT			CODE
ELEMENT	CAPACITY	MOUNTING	
Single H ₂ O-sorb element	540 ml	Standard mounting single filter head	A
Single H ₂ O-sorb element	540 ml	Alternative mounting single filter head	B
Dual H ₂ O-sorb element	2 x 540 ml	Standard mounting double filter head	C

TABLE 11 DRIPTRAY - OPTION		CODE
No Drip tray		0
Drip tray		D



OLUH*A & OLUH*B

HEATED OFF-LINE FILTER UNIT

HEATED OFF-LINE FILTERS

RMF Systems radial micro filter units are characterised by their extremely efficient filter elements with a fineness of 0.5 micron. The Off-line filter units with pre-heating are developed specially for cold hydraulic and lubricating systems.

The electric pre-heating ensures that the cold and/or high viscosity fluid is brought to a temperature with a suitable filtration viscosity. Off-line filters with pre-heating can be applied to new or existing installations. The integrated pump-motor combination draws fluid from the reservoir, pumps it through a heating element, filters it and returns it to the tank. The heating is thermostat controlled and adjustable to any required fluid temperature. The heating is effected by a 'flow-through' principle, preventing 'burning' or thermal overloading of the oil.

The Heated Off-line filters can continue to work even when the main system is not in use. Element change can also be done without interfering the main system.

APPLICATIONS

RMF Off-line filter units with pre-heating can be applied to any industrial application where it is necessary to heat the oil and maintain it at a particular temperature, such as hydraulically operated bridges and gear boxes in the wind power energy industry.

ADVANTAGES

- ▶ Extremely clean oil due to the high filtration efficiency $\beta_{0.5} \geq 200$, $\beta_2 \geq 2,330$.
- ▶ Prevention of channel forming by radial filtration direction.
- ▶ Increased dirt holding capacity.
- ▶ Large water holding capacity.
- ▶ Compact and easy-maintenance design.
- ▶ Environmentally friendly elements.
- ▶ Longer usable life for oil and components.



Specification OLUH1



PRODUCT DETAILS			
	OLUH1A	OLUH1B	OLUH1B
Nominal Flow	Approx. 2,9 l/min with 2kW heater Consult RMF Systems for 4kW heater and flows exceeding 2,9 l/min		
Standard Max. Oil Temperature ¹	80°C		
Max. pressure filter housing	20 bar		
Inlet connection ²	3/8" BSP female	1/2" BSP female	
Outlet connection	1/2" BSP female		
Heater Capacity	2 kW	2 kW	4 kW
Power supply Electric Motor	Various electrical power supplies possible (see ordering code)		
Suitable elements ³	30HB, 30HV, 30NB, 30NV, 30G1B, 30G1V, 30G3B, 30G3V, 30A5B	30HB, 30HV, 30NB, 30NV, 60HB 60HV, 60NB, 60NV, 30G1B, 30G1V, 30G3B, 30G3V, 30A5B, 60G1B, 60G1V, 60G3B, 60G3V	
By-pass openings pressure	6,2 bar (at 0 bar back pressure)		
Pump safety valve	15 bar		
Max. Tank volume	± 1,350 l	± 2,700 l	
Fluid Compatibility ⁴	Hydraulic fluids according ISO 2943		
Approximate weight	24 kg	28 kg	30 kg

¹For other oil temperatures please contact RMF Systems

²Inlet Connections are pump dependent. Please contact RMF Systems or your distributor.

³For complete specifications of the RMF Systems Filter elements see page 41

⁴For other fluids, please contact RMF Systems

Dimensions OLUH1

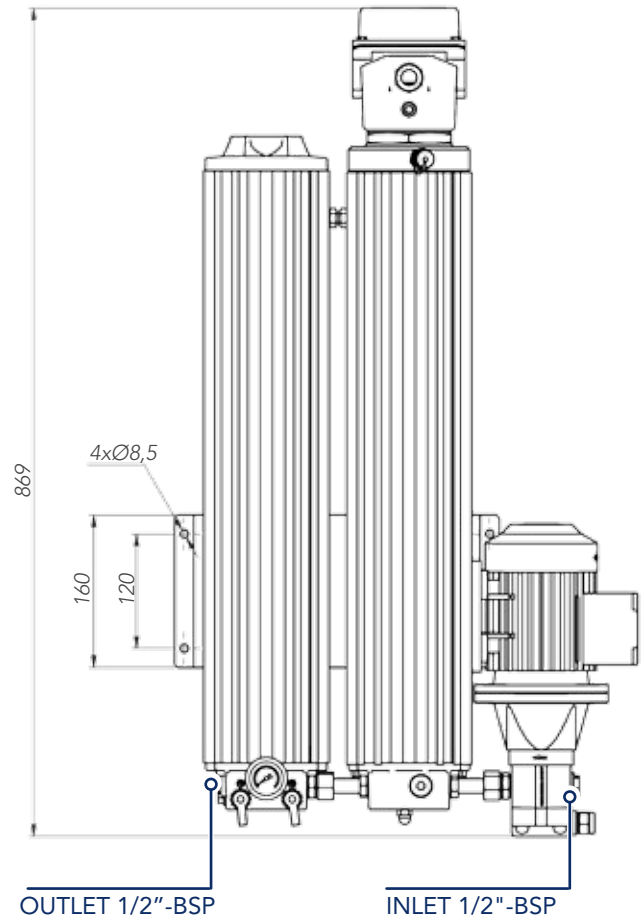
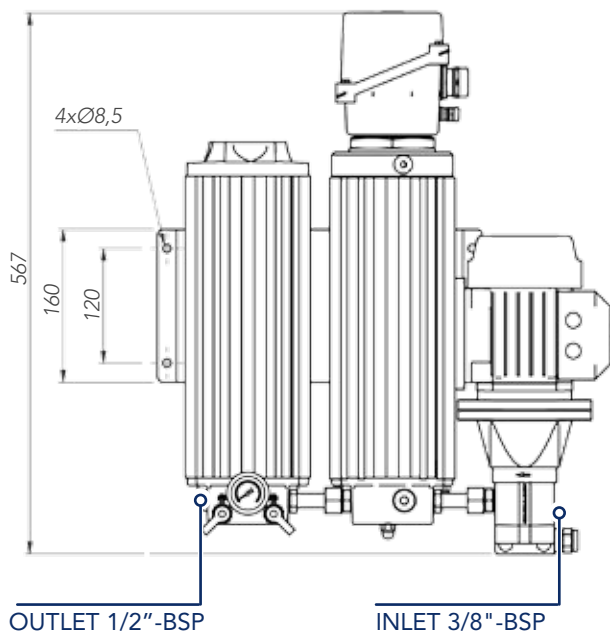
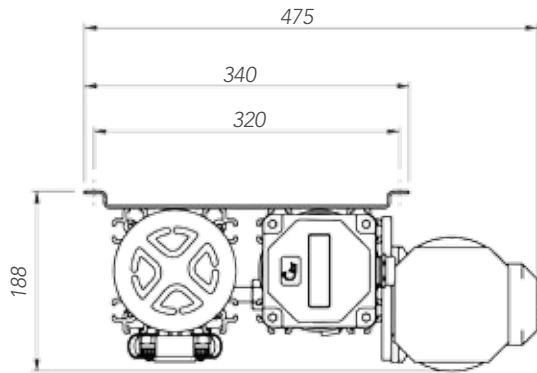

Ordering Code

OLUH A & B

YOUR OFF-LINE FILTER ORDERING CODE

TABLE 1	TABLE 2	TABLE 3	TABLE 4	TABLE 5	TABLE 6	TABLE 7	TABLE 8	TABLE 9	TABLE 10
OLUH									

TABLE 1 - BASIC CONFIGURATION

		CODE
Off-line heated unit	Industrial applications	OLUH

TABLE 2 - HOUSING CONFIGURATION

		CODE
HOUSING CONFIGURATION	TYPICAL RESERVOIR SIZE	
Single housing (single length)	Suitable for 1350 l reservoir	1A
Twin housing (single length)	Suitable for 2700 l reservoir	2A
Single housing (double length)	Suitable for 2700 l reservoir	1B

TABLE 3 - LENGTH ELEMENT

	CODE
300 mm	30
600 mm	60

TABLE 4 - FILTER MATERIAL

	CODE
Cellulose 0.5 micron, silicon bottom seal	H
Cellulose 0.5 micron, NO silicon bottom seal	N
Glass fiber with polymer, 5 micron, $\beta_5 \geq 200$	A5
ALSO SUITABLE FOR WATER GLYCOL	
Glass fiber, 1 micron $\beta_1 \geq 200$	G1
Glass fiber, 3 micron $\beta_3 \geq 200$	G3

TABLE 5 - SEAL MATERIAL

	CODE
Buna-N (standard)	B
Viton	V

TABLE 6 - E-MOTOR OPTIONS

	CODE
230 / 400 VAC 50 Hz / 3 phase (standard)	0
255 / 460 VAC 60 Hz / 3 phase	
230 VAC 50 Hz / 1 phase	A
110 VAC 50 Hz / 1 phase	C
110 VAC 60 Hz / 1 phase	D
230 / 400 VAC 50 Hz, IP65 / 3 phase	E
230 VAC 60 Hz / 1 phase	F
690 VAC 50 Hz / 3 phase	H

TABLE 7 - PUMP OPTIONS		CODE
STANDARD FOR 50 HZ MOTOR		
1.6 cc/rev. group 1	OLU1A	00
3.2 cc/rev. group 1	OLU2A / OLU1B	10
1.1 cc/rev. group 1		60
STANDARD FOR 60 HZ MOTOR		
1.1 cc/rev. group 1	OLU1A	01
2.7 cc/rev. group 1	OLU2A / OLU1B	11
4,00 cc/rev screw pump		S1

TABLE 8 - INDICATOR		CODE
Pressure gauge (standard)		0
Additional electr. switch		1
Additional Δp switch		2

TABLE 9 - EXTRA OPTIONS		CODE
No options		0
Motor / pump / heater left side mount		2
Incl. motor protection / start stop		4
Incl. motor protection / start stop / by-pass ext.		5
Incl. custom built electrical control box		6
RMF magnet filter		7

TABLE 10 - HEATER OPTIONS		CODE
HEATER OPTIONS	STANDARD FOR	
2000 W/L = 300 mm / voltage equal to e-motor	OLU1A / OLU2A	0
4000 W/L = 600 mm / voltage equal to e-motor	OLU1B	1
2 pcs. 2000 W/L = 300 mm / voltage equal to e-motor	Special	2
2 pcs. 4000 W/L = 600 mm / voltage equal to e-motor	Special	3



SMART OFF-LINE UNITS

THE SUCCESSFUL APPLICATION OF DEPTH FILTRATION ON HYDRAULIC AND LUBE OIL SYSTEMS AND THE GROWING DEMAND FOR CONDITION MONITORING SYSTEMS TO OPTIMIZE THE APPLICATION OF THE FILTERS HAS LED TO THE DEVELOPMENT OF THE NEXT GENERATION IN RMF SYSTEMS TECHNOLOGY: RMF OFF-LINE FILTERS WITH AN INTEGRATED CMS UNIT.

ONE ECONOMICAL INSTALLATION

Smart Off-line Units enable machine operators to keep their hydraulic oil clean and monitor contamination levels real-time in one economical installation.

The integrated CMS (Condition Monitoring Sensor) can be combined with the entire selection of Off-line Units in the RMF systems range.

CONFIGURATIONS

Specially designed for industrial hydraulic installations, the RMF Smart Off-line Units are available in single or multiple housing configurations.

The Smart Off-line Units can be easily mounted to new and existing installations, and combine all advantages of RMF Off-line filters and CMS in one efficient installation. The CMS related product options are equally applicable to the Smart Off-line filter Units.

INTEGRATED CONTAMINATION MONITORING SYSTEM (CMS)

The CMS in-line contamination monitor automatically measures and displays particulate contamination, moisture and temperature levels in various hydraulic fluids where ongoing measurement or analysis is required.

- ▶ Measures and displays the international standard formats ISO 4406:1999, NAS 1638, AS 4059E and ISO 11218
- ▶ 8 Channels solid contamination measurement
- ▶ Moisture (RH) & Temperature option
- ▶ 9-36 Volt DC
- ▶ Large backlit display and keypad
- ▶ Multicolour LED status alarms
- ▶ Programmable test times
- ▶ Manual / Auto operation
- ▶ Programmable alarm relays
- ▶ PC/ PLC Operation
- ▶ Windows based software included
- ▶ RS 485 communication standard / USB optional

APPLICATIONS

- ▶ Steel industry
- ▶ Plastic moulding industry
- ▶ Maritime industry
- ▶ Petro chemical industry
- ▶ Paper industry

THE BENEFITS

- ▶ Extremely clean oil due to high filtration efficiency
- ▶ Permanent reporting of contamination levels
- ▶ Permanent reporting of moisture RH % and temperature
- ▶ Prevention of channel forming by radial filtration direction
- ▶ Increased flow capacity
- ▶ Large dirt holding capacity
- ▶ Large water holding capacity
- ▶ Compact and easy-maintenance design
- ▶ Environmentally friendly elements available
- ▶ Longer life for oil and components
- ▶ Reduces cost of ownership

Specification OLU1



PRODUCT DETAILS		
	OLUS1A	OLUS1B
Nominal Flow	2,1 l/min	4,2 l/min
Standard Max. Oil Temperature ¹	80°C	
Max. pressure filter housing	20 bar	
Inlet connection ²	3/8" BSP female	1/2" BSP female
Outlet connection	1/2" BSP female	
Power supply Electric Motor	Various electrical power supplies possible (see ordering code)	
Suitable elements ³	30HB, 30HV, 30NB, 30NV, 30G1B, 30G1V, 30G3B, 30G3V, 30A5B	30HB, 30HV, 30NB, 30NV, 60HB 60HV, 60NB, 60NV, 30G1B, 30G1V, 30G3B, 30G3V, 30A5B, 60G1B, 60G1V, 60G3B, 60G3V
By-pass openings pressure	6,2 bar (at 0 bar back pressure)	
Pump safety valve	15 bar	
Max. Tank volume	±1,350 l	± 2,700 l
Fluid Compatibility ⁴	Hydraulic fluids according ISO 2943	
Approximate weight	16 kg	20 kg

¹For other oil temperatures please contact RMF Systems

²Inlet Connections are pump dependent. Please contact RMF Systems or your distributor.

³For complete specifications of the RMF Systems Filter elements see page 41

⁴For other fluids, please contact RMF Systems

Dimensions OLUS1

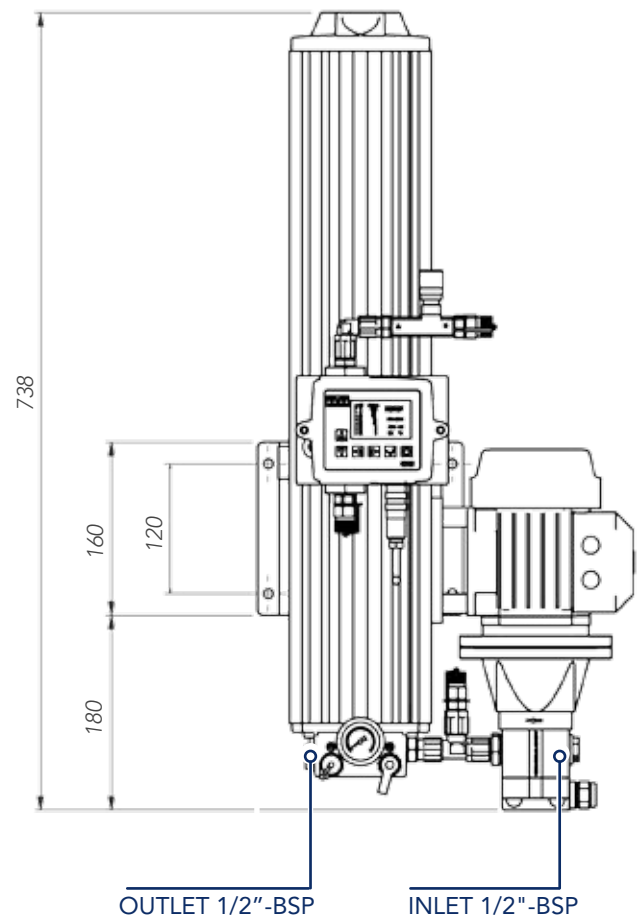
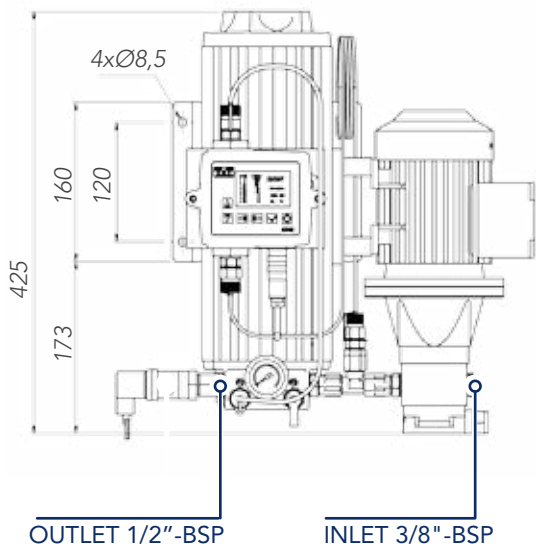
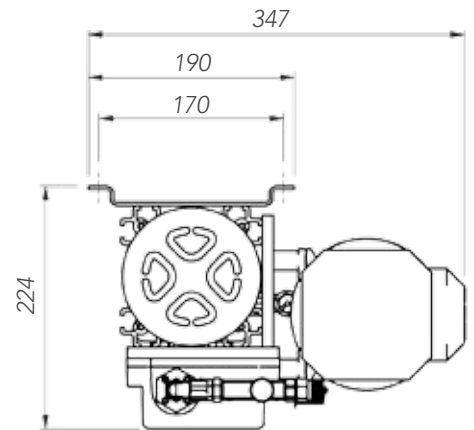
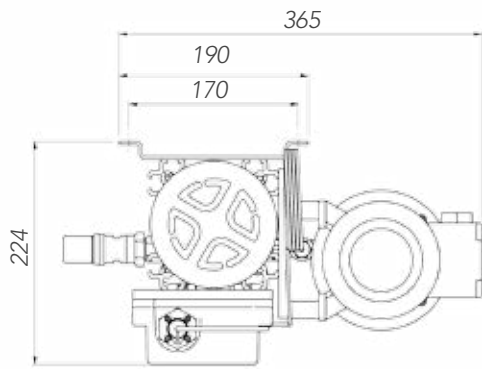

Specification OLUS2



PRODUCT DETAILS

	OLUS2A	OLUS2B
Nominal Flow	4,2 l/min	8,4 l/min
Standard Max. Oil Temperature ¹	80°C	
Max. pressure filter housing	20 bar	
Inlet connection ²	½" BSP female	½" BSP female
Outlet connection	½" BSP female	
Power supply Electric Motor	Various electrical power supplies possible (see ordering code)	
Suitable elements ³	30HB, 30HV, 30NB, 30NV, 30G1B, 30G1V, 30G3B, 30G3V, 30A5B	30HB, 30HV, 30NB, 30NV, 60HB 60HV, 60NB, 60NV, 30G1B, 30G1V, 30G3B, 30G3V, 30A5B, 60G1B, 60G1V, 60G3B, 60G3V
By-pass openings pressure	6,2 bar (at 0 bar back pressure)	
Pump safety valve	15 bar	
Max. Tank volume	±2,700 l	± 5,400 l
Fluid Compatibility ⁴	Hydraulic fluids according ISO 2943	
Approximate weight	22 kg	32 kg

¹For other oil temperatures please contact RMF Systems

²Inlet Connections are pump dependent. Please contact RMF Systems or your distributor.

³For complete specifications of the RMF Systems Filter elements see page 41

⁴For other fluids, please contact RMF Systems

Dimensions OLUS2

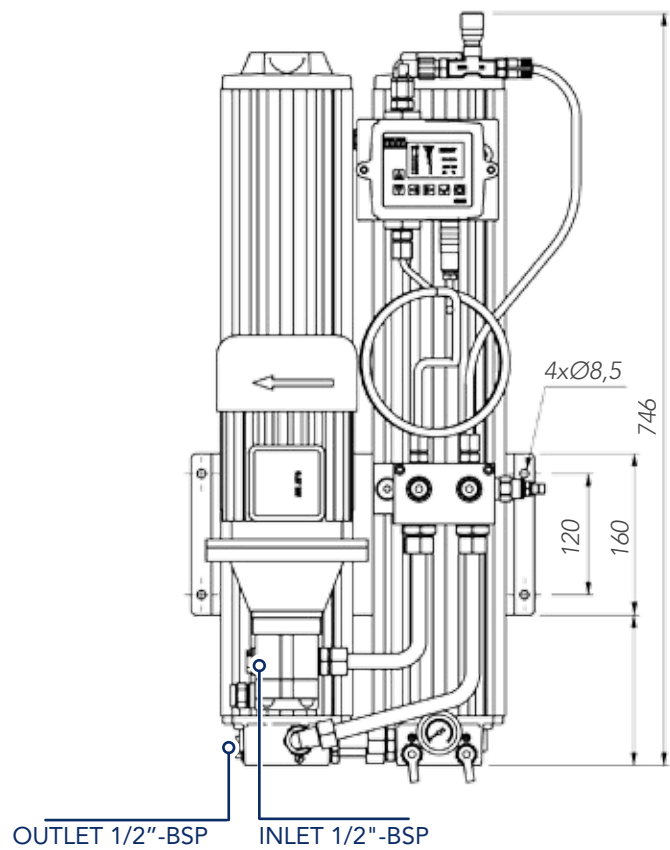
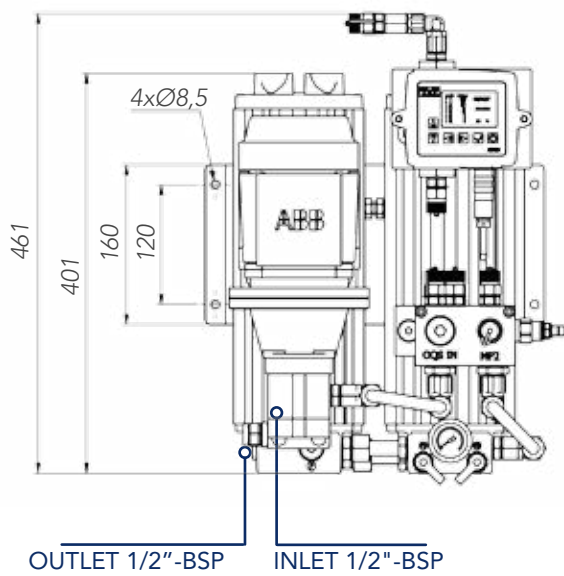
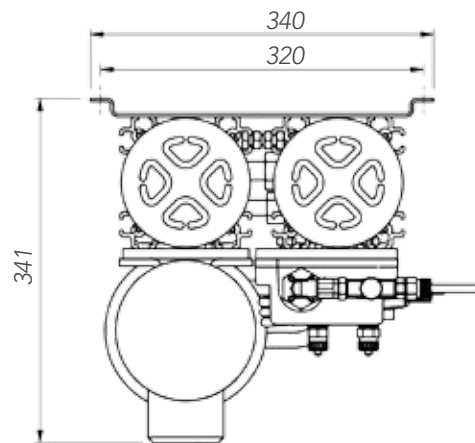
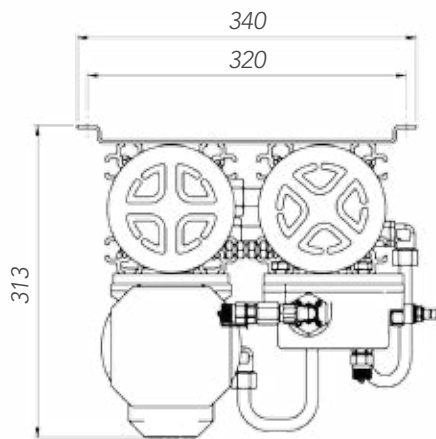

Specification OLUS4



PRODUCT DETAILS		
	OLUS4A	OLUS4B
Nominal Flow	8,4 l/min	16,3 l/min
Standard Max. Oil Temperature ¹	80°C	
Max. pressure filter housing	20 bar	
Inlet connection ²	½" BSP female	¾" BSP female
Outlet connection	EW 22L	
Power supply Electric Motor	Various electrical power supplies possible (see ordering code)	
Suitable elements ³	30HB, 30HV, 30NB, 30NV, 30G1B, 30G1V, 30G3B, 30G3V, 30A5B	30HB, 30HV, 30NB, 30NV, 60HB 60HV, 60NB, 60NV, 30G1B, 30G1V, 30G3B, 30G3V, 30A5B, 60G1B, 60G1V, 60G3B, 60G3V
By-pass openings pressure	6,2 bar (at 0 bar back pressure)	
Pump safety valve	15 bar	
Max. Tank volume	± 5,400 l	± 10,800 l
Fluid Compatibility ⁴	Hydraulic fluids according ISO 2943	
Approximate weight	39 kg	61 kg

¹For other oil temperatures please contact RMF Systems

²Inlet Connections are pump dependent. Please contact RMF Systems or your distributor.

³For complete specifications of the RMF Systems Filter elements see page 41

⁴For other fluids, please contact RMF Systems

Dimensions OLUS4

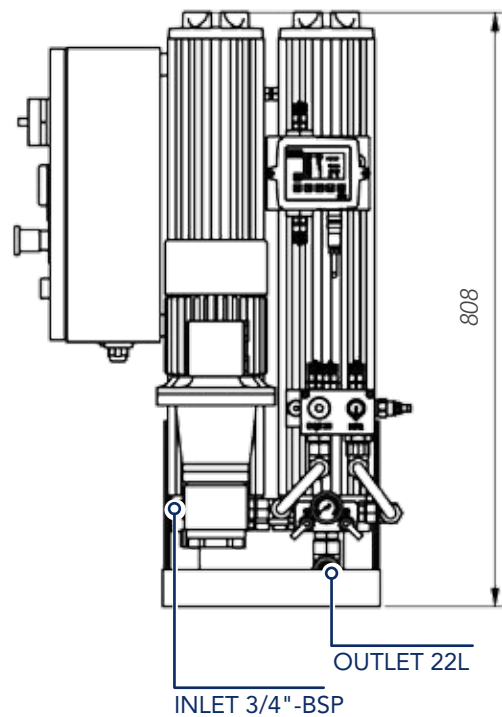
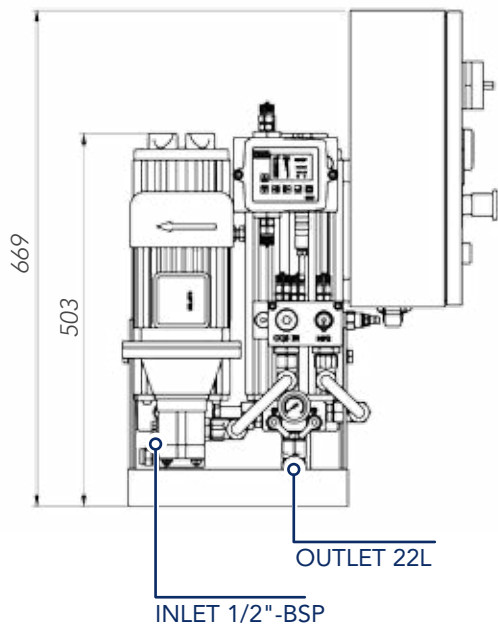
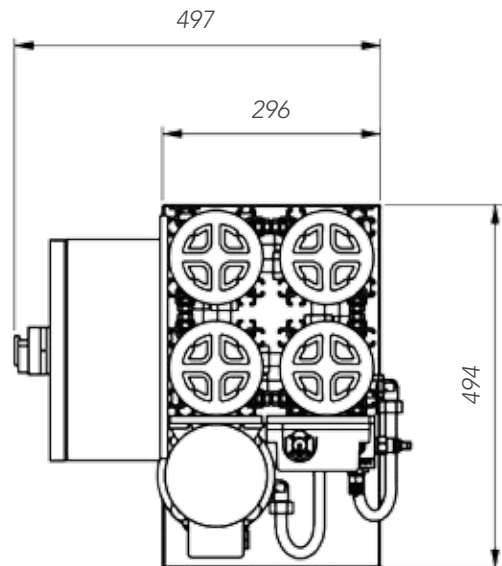
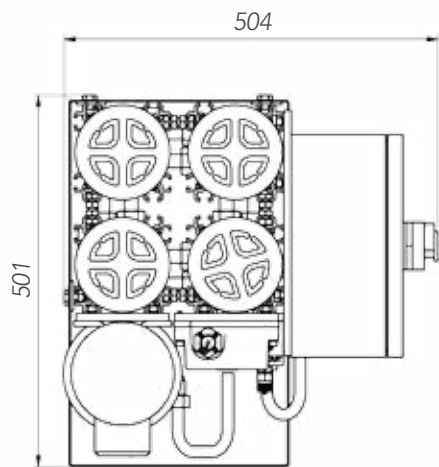

Ordering Code

OLUS A & B

YOUR OFF-LINE FILTER ORDERING CODE

TABLE 1	TABLE 2	TABLE 3	TABLE 4	TABLE 5	TABLE 6	TABLE 7	TABLE 8	TABLE 9	TABLE 10	TABLE 11
OLUS					0					

TABLE 1 - BASIC CONFIGURATION

		CODE
Off-line unit with integrated contamination monitoring system	Industrial applications	OLUS

TABLE 2 - HOUSING CONFIGURATION

HOUSING CONFIGURATION	TYPICAL RESERVOIR SIZE	CODE
Single housing (single length)	Suitable for 1350 l reservoir	1A
Twin housing (single length)	Suitable for 2700 l reservoir	2A
Quadruple housing (single length)	Suitable for 5400 l reservoir	4A
Single housing (double length)	Suitable for 2700 l reservoir	1B
Twin housing (double length)	Suitable for 5400 l reservoir	2B
Quadruple housing (double length)	Suitable for 10800 l reservoir	4B

TABLE 3 - LENGTH ELEMENT

	CODE
300 mm	30
600 mm	60

TABLE 4 - FILTER MATERIAL

	CODE
Cellulose 0.5 micron, silicon bottom seal	H
Cellulose 0.5 micron, NO silicon bottom seal	N
Glass fiber, 1 micron $\beta_1 \geq 200$	G1
Glass fiber, 3 micron $\beta_3 \geq 200$	G3

TABLE 5 - SEAL MATERIAL

	CODE
Buna-N (standard)	B
Viton	V

TABLE 6 - E-MOTOR OPTIONS

	CODE
230 / 400 VAC 50 Hz / 3 phase (standard)	0
255 / 460 VAC 60 Hz / 3 phase	

TABLE 7 - PUMP OPTIONS

50 HZ APPLICATION	STANDARD FOR	E-MOTOR	CODE
1.6 cc/rev. group 1	OLUS1A	0.18 kW	00
3.2 cc/rev. group 1	OLUS2A / OLUS1B	0.18 kW	10
5.8 cc/rev. group 1 (standard)	OLUS4A / OLUS2B	0.37 kW	20
8.0 cc/rev. group 2		0.60 kW	30
12.0 cc/rev. group 2	OLUS4B	0.60 kW	40
1.1 cc/rev. group 1		0.18 kW	60

TABLE 7 - PUMP OPTIONS			CODE
60 HZ APPLICATION			
1.1 cc/rev. group 1	OLUS1A	0.18 kW	01
2.7 cc/rev. group 1	OLUS2A / OLUS1B	0.18 kW	11
4.8 cc/rev. group 1	OLUS4A / OLUS2B	0.37 kW	21
10 cc/rev. group 2	OLUS4B	0.60 kW	41
STANDARD FOR 50/60 HZ APPLICATION LOW OR HIGH VISCOSITIES		E-MOTOR	
Approx. 4.3 l/min (@50 Hz) aluminium screw pump with pump safety valve (viton)		0.37 kW	S1
Approx. 4.3 l/min (@50 Hz) steel screw pump with pump safety valve and magnetic coupling (viton)		0.37 kW	S2

TECHNICAL NOTE				
E-MOTOR	0.18 kW	0.29 kW	0.37 kW	0.60 kW
50 HZ (3-PHASE)	3.2 cc/rev.	5.0 cc/rev.	5.8 cc/rev.	12.0 cc/rev.
60 HZ (3-PHASE)	2.5 cc/rev.	3.15 cc/rev.	5.0 cc/rev.	10.0 cc/rev.

TABLE 8 - INDICATOR		CODE
Pressure gauge (standard)		0
Additional electr. switch		1
Additional Δp switch		2
OQS		4
OQS + display		5
OQS prepared		6

TABLE 9 - EXTRA OPTIONS		CODE
No options		0
Incl. control box with on/off, motor protection relais and 24VDC power supply for CMS unit		1
Incl. control box with on/off, emergency stop button, motor protection relais, 24VDC power supply for CMS unit and integrated Single RS485-to-USB converter for data transfer.		2
Option 2 with Single RS485-to-Ethernet converter for data transfer.		3
Option 2 with Double RS485-to-USB converter for data transfer.		4*
Option 3 with Double RS485-to-Ethernet converter for data transfer.		5*
RMF magnet filter		7

* Only suitable in combination with option 4, 5 or 6 in Table 8.

TABLE 10 - CMS OPTIONS			CODE
CMS-W-M-K-R-G1	CMS unit with keypad with relays with moisture sensor	Mineral oil	0
CMS-0-M-K-R-G1	CMS unit with keypad with relays without moisture sensor	Mineral oil	1
CMS-W-M-0-R-G1	CMS unit without keypad with relays with moisture sensor	Mineral oil	2
CMS-0-M-0-R-G1	CMS unit without keypad with relays without moisture sensor	Mineral oil	3
CMS-0-N-K-R-G1	CMS unit with keypad with relays without moisture sensor	Off-shore and selected water based fluids	4

TABLE 11 - DRIPTRAY		CODE
No Drip tray		0
Drip tray		D

Dimensions Drip tray

OLU1

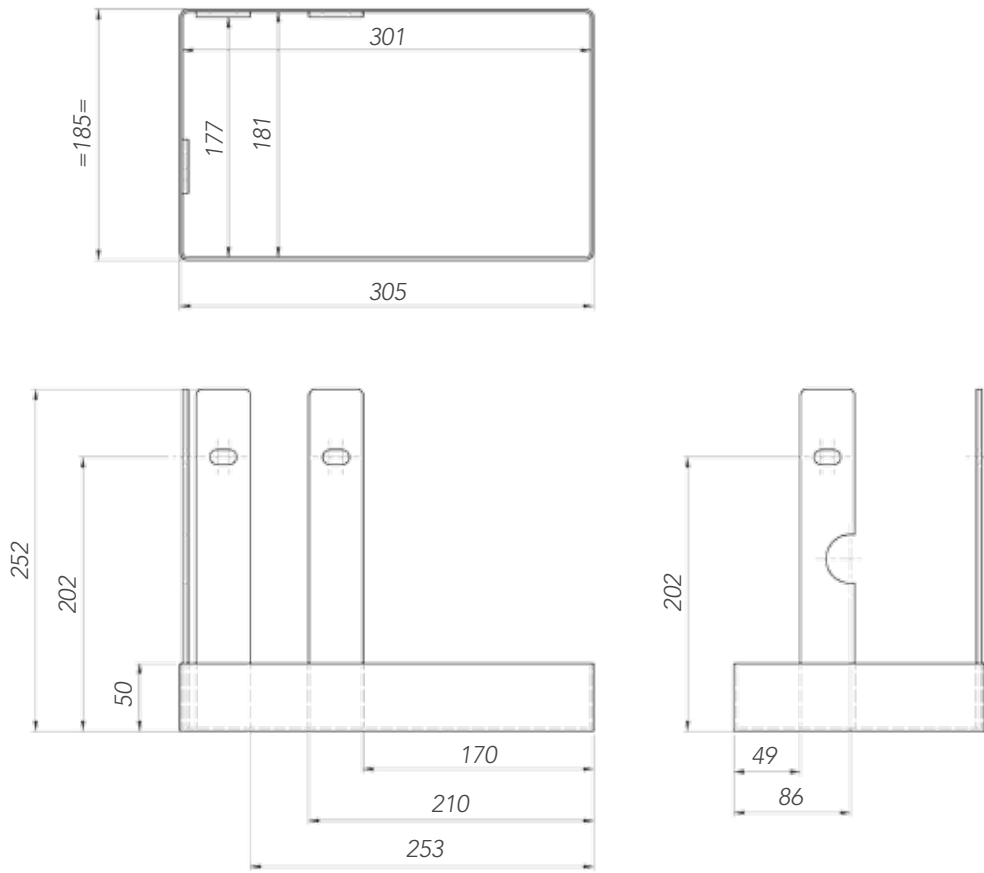

OLU2

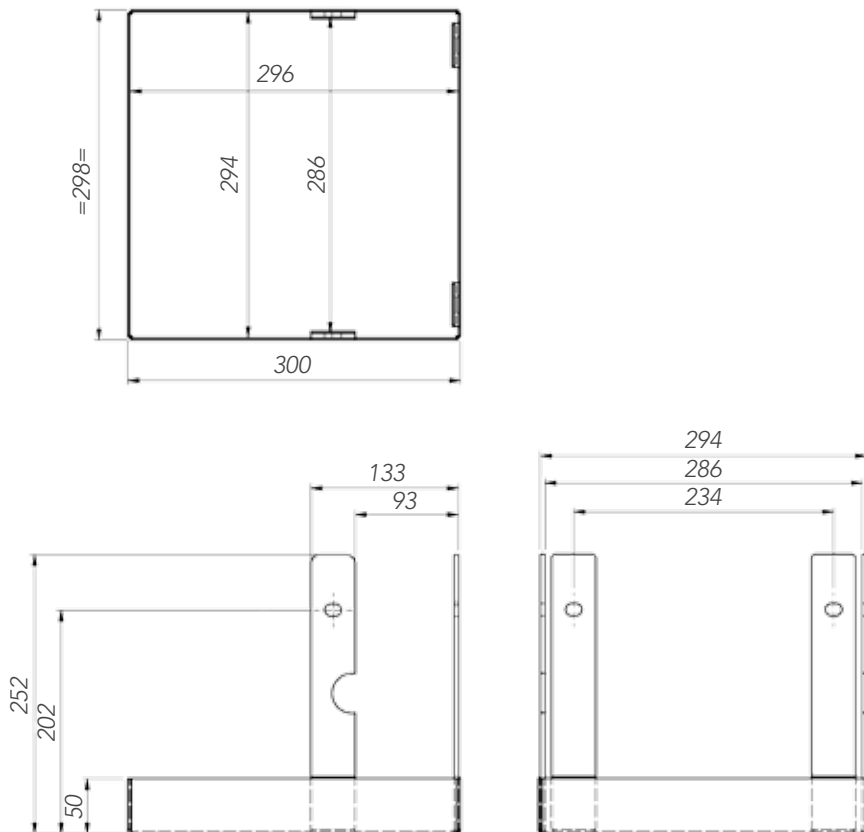

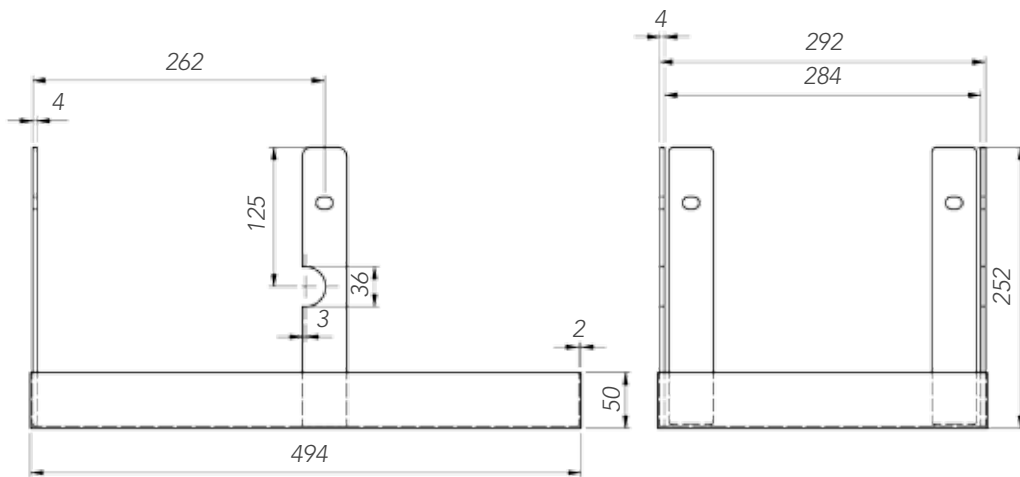
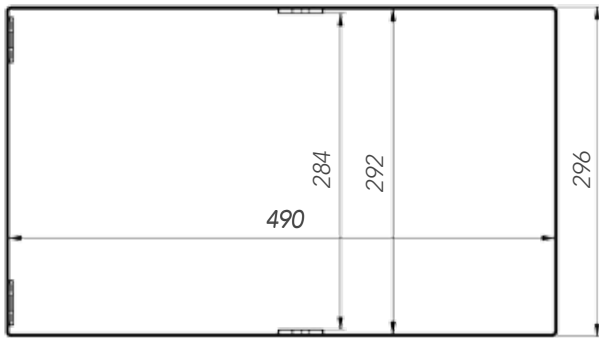

DETAILED VIEW STRIPS

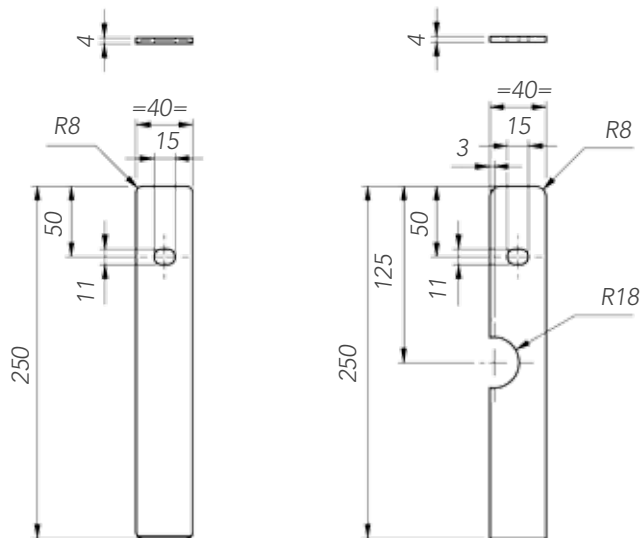

Filter Elements

The principle of the RMF Systems filters is based on the unique original filter elements. With a choice of filter fineness down to 0,5 micron they have the capacity to remove even the smallest of dirt particles from the oil. RMF Systems offers a wide range of elements in micron sizes, filter media and fluid compatibility. Contact your local distributor for specific fluids. Combi-elements (water and solid particle retention) complement the unique range.



CELLULOSE ELEMENTS

The RMF Systems Cellulose filter elements are unique in their design. They consist of several hundred layers of cellulose fibre which are rolled on a perforated centre tube. The micro filter element works as a fine filter through which oil passes, trapping solid particles throughout all the layers of cellulose. The filter medium is also capable of absorbing water, adding the benefit of water removal from the oil. RMF Systems cellulose elements are extremely efficient and have a large dirt holding capacity.



FIBREGLASS ELEMENTS

RMF Systems offers a range of Fibreglass filter elements in a fineness of 1 micron and 3 micron. The Fibreglass filter elements (conventional pleated construction) are extremely efficient and have a large dirt holding capacity. These filter elements are particularly suited for gearbox applications where high viscosity fluids limit the use of the cellulose elements.

WATER SORB FILTER INSERTS

RMF Systems offers a specially designed Water Sorb combination filter element: water absorbing and particle retention. The elements have layers of polymers in between layers of fibreglass, creating a unique media to remove both water and solid particles.



WATER SORB SPIN-ON ELEMENTS

RMF Systems offers a specially designed Spin-on filter, the H₂O Sorb for water absorbing and particle retention. This Spin-on filter element with a fineness of 20 micron is constructed of a unique medium containing water-absorbing polymer which chemically bonds water.

Specification Filter Elements

FILTER ELEMENTS					
	30HB	30HV	30NB	30NV	30XV
Filter material	Cellulose	Cellulose	Cellulose	Cellulose	Cellulose
Seal Material	NBR	FPM	NBR	FPM	FPM
Filter efficiency	$\beta 2 \geq 2331$	$\beta 2 \geq 2331$	$\beta 2 \geq 2331$	$\beta 2) \geq 2331$	$\beta 2) \geq 2331$
Water absorption	150 ml	150 ml	150 ml	150 ml	150 ml
Dirt holding capacity	40 gram MTD	40 gram MTD	40 gram MTD	40 gram MTD	40 gram MTD
	60HB	60HV	60NB	60NV	60XV
Filter material	Cellulose	Cellulose	Cellulose	Cellulose	Cellulose
Seal Material	NBR	FPM	NBR	FPM	FPM
Filter efficiency	$\beta 2 \geq 2331$	$\beta 2 \geq 2331$	$\beta 2 \geq 2331$	$\beta 2 \geq 2331$	$\beta 2 \geq 2331$
Water absorption	300 ml	300 ml	300 ml	300 ml	300 ml
Dirt holding capacity	80 gram	80 gram	80 gram	80 gram	80 gram
	30G1B	30G1V	30G3B	30G3V	
Filter material	Glass fibre	Glass fibre	Glass fibre	Glass fibre	
Seal Material	NBR	FPM	NBR	FPM	
Filter efficiency	$\beta 1 = 200$	$\beta 1 = 200$	$\beta 3 = 200$	$\beta 3 = 200$	
Water absorption	-	-	-	-	
Dirt holding capacity	230 gram	230 gram	269 gram	269 gram	
	60G1B	60G1V	60G3B	60G3V	
Filter material	Glass fibre	Glass fibre	Glass fibre	Glass fibre	
Seal Material	NBR	FPM	NBR	FPM	
Filter efficiency	$\beta 1 = 200$	$\beta 1 = 200$	$\beta 3 = 200$	$\beta 3 = 200$	
Water absorption	-	-	-	-	
Dirt holding capacity	465 gram	465 gram	535 gram	535 gram	
	30A5B	30A5V	60A5B	60A5V	
Filter material	Glass fibre and Polymer	Glass fibre and Polymer	Glass fibre and Polymer	Glass fibre and Polymer	
Seal Material	NBR	FPM	NBR	FPM	
Filter efficiency	$\beta 5(c) = 200$	$\beta 5(c) = 200$	$\beta 5(c) = 200$	$\beta 5(c) = 200$	
Water absorption	350 ml	350 ml	720 ml	720 ml	
Dirt holding capacity	205 gram	205 gram	415 gram	415 gram	
WATER SORB SPIN-ON ELEMENTS					
Water absorbing material	Polymer's				
Seal Material	FPM				
Water absorption capacity	500 ml				



Contamination Monitoring Sensor CMS

The CMS in-line contamination monitor automatically measures and displays particulate contamination, moisture and temperature levels in various hydraulic fluids. It is designed specifically to be mounted directly to systems where ongoing measurement or analysis is required, and where space and costs are limited.

SPECIFICATION

LED Based Light Extinction
Automatic Optical Particle
Counter

Analysis Range

ISO 4406:1999 code 0 to 25
NAS 1638 Class 00 to 12
AS4059 Rev.E. Table 2
Sizes A-F: 000 to 12
(lower Limits Test Time
dependent)

Measurement in 8 channels with particle sizing

4,6,14,21,25,38,50,70 $\mu\text{m}(c)$
to revised ISO 4406 Standard

CMS WATER EN TEMPERATURE SENSOR

The water sensor option measures water content using a capacitive RH (relative humidity) sensor. The results is expressed as percentage saturation.

100% RH corresponds to the point at which free water exists in the fluid, i.e. the fluid is no longer able to hold the water in a dissolved solution.

SOFTWARE

All CMS Units are supplied with software that can be installed on you PC. The results can be downloaded from the CMS to your computer. When the CMS is connected to the PC, it can be controlled directly by the software.

Alternatively historical results can be downloaded from the CMS's in built memory. The CMS memory has space for around 4000 log entries, when full, the oldest log entry is overwritten.

- ▶ Which test are logged, and when, are determined by the log settings
- ▶ Each log entry is time-stamped and contains the CMS serial number, so that it can be identified later.

CMS ALARM RELAY STATUS LED

All CMS versions have a multicoloured indicator on the front panel, which is used to indicate the status or alarm state. The alarm thresholds can be set from the supplied software via the serial interfaces.



CMS "USB-I" CONNECTOR

This is a ready-made solution for easily connecting a PC/ Laptop to the CMS. It comprises of a USB:RS485 interface with a terminal block pre-wired to connect directly to the CMS. An extra terminal block is provided for any customer wanting to wire external devices through two solid state relays. An external DC adapter can be used to power the complete system, or if the computer is always connected during use, power can be taken directly from the USB cable. Powered PC / Laptops only.

Oil Quality Sensor

OQS

The Oil Quality sensor (OQS) from RMF Systems puts you in control with real-time monitoring of oil degradation due to contamination and water ingress. Expensive oil changes are now based on oil condition, not on historical schedule.

ENVIRONMENTAL

Strict schedule based maintenance programmes have several downsides. Environmental experts argue that the greatest of these is the preventable waste. The Oil Quality Sensor (OQS) real-time monitoring sensor makes extending the oil service life effortless.

MARKET LEADING

The Oil Quality Sensor (OQS) is 60 times more sensitive to oil degradation than any other dielectric constant measuring sensor.

INTELLIGENT

The OQS measures the energy loss component of oil permittivity. All contaminants such as metallic particles, soot, water, oxidization, glycol and particularly burnt fuel dilution increase this measured value.



UNIVERSAL

Reliably measures oil degradation in all industrial equipments, including;

- ▶ Diesel and petrol engines
- ▶ Compressors
- ▶ Industrial gear reducers
- ▶ Wind turbines
- ▶ Generator sets
- ▶ Hydraulic systems

BENEFITS

- ▶ Reduced maintenance cost
- ▶ Extended oil change intervals
- ▶ Scheduled downtime intervals for increased productivity
- ▶ Reduced waste oil cost
- ▶ Improved equipment reliability
- ▶ Low cost investment tool
- ▶ Reduced carbon foot print
- ▶ Reduces total cost of ownership

OQS FACTS

- ▶ Robust design
- ▶ Resistant to high fluid temperatures, -40 C ° to 120 C °
- ▶ Resistant to fluid pressures up to 20 bar



OIL QUALITY DISPLAY

The Oil Quality Display is a simple but powerful device which allows you to read the quality and temperature of the oil from a sensor without a PC.

This enables you to set up the display box on site and then be able to see the oil quality and temperature readings as required. Use an Android app to connect your Smartphone with the OQD smart via Bluetooth. With it being IP67 rated (when connected) you do not need to worry about the need to keep it in a dry place. Also with it being made from polycarbonate it is a strong durable product which cannot be damaged easily. The new 'Rate of Change' feature allows you to easily monitor the degradation of oil over a programmable period of time.

RMF Systems Electric Motors

GENERAL INFORMATION ABOUT ELECTRIC MOTORS

Electric motors are manufactured according to international standards under IEC and are fulfilling the requirement of the EC Directive 2005/32 (IE2-directive). All the electric motors have an IP 55 certification.



1 PHASE ELECTRIC MOTORS

DESCRIPTION	VOLTAGE	FREQUENCY	POLES	RPM
RMF 0,18 kW	110 VAC	50 / 60 Hz	4	1370 / 1640
RMF 0,18 kW	230 VAC			
RMF 0,37 kW	110 VAC			
RMF 0,37 kW	230 VAC			

3 PHASE ELECTRIC MOTORS

DESCRIPTION	VOLTAGE	FREQUENCY	POLES	RPM
RMF 0,15 kW	200 / 346 VAC	50 Hz	4	1340
RMF 0,14 kW	200 / 346 VAC	60 Hz		1610
RMF 0,18 kW	230 / 400 VAC	50 Hz		1340
RMF 0,22 kW	280 / 480 VAC	60 Hz		1610
RMF 0,18 kW	400 / 690 VAC	50 Hz		1360
RMF 0,18 kW	400 / 690 VAC	60Hz		1650
RMF 0,18 kW	460 VAC	50Hz		1800
RMF 0,28 kW	200 / 346 VAC	60 Hz		1640
RMF 0,31 kW	200 / 346 VAC	50 Hz		1380
RMF 0,44 kW	280 / 480 VAC	60 Hz		1640
RMF 0,37 kW	230 / 400 VAC	50 Hz		1380
RMF 0,55 kW	230 / 400 VAC	50 Hz		1360
RMF 0,66 kW	280 / 480 VAC	60 Hz		1620
RMF 0,46 kW	200 / 346 VAC	50 Hz		1360
RMF 0,42 kW	200 / 346 VAC	60 Hz		1620

RMF Systems Pumps



THE RMF SYSTEMS GEAR PUMPS ARE EQUIPPED WITH A PRESSURE RELIEF VALVE ON THE SUCTION SIDE OF THE PUMP. THE SAFETY OF THE PRESSURE RELIEF VALVE IS SET TO 15 BAR.

PUMP SPECIFICATION	
50 HZ APPLICATION	
	1.6 cc/rev.
	3.2 cc/rev.
	5.8 cc/rev.
	8.0 cc/rev.
	12.0 cc/rev.
	1.1 cc/rev.

PUMP SPECIFICATION	
60 HZ APPLICATION	
	1.1 cc/rev.
	2.7 cc/rev.
	4.8 cc/rev.
	10 cc/rev.

TECHNICAL NOTE				
E-MOTOR	0.18 KW	0.29 KW	0.37 KW	0.60 KW
50 HZ (3-PHASE)	3.2 cc/rev.	4,8 cc/rev.	5.8 cc/rev.	12.0 cc/rev.
60 HZ (3-PHASE)	2.7 cc/rev.	3,2 cc/rev.	4,8 cc/rev.	10.0 cc/rev.

RMF Systems Heater



HEATER ELEMENT SPECIFICATION		
DESCRIPTION	2KW HEATER	4KW HEATER
Power	2000 Watt	4000 Watt
Voltage	254/440 VAC	
Maximum temperature	100° C	
Ingress Protection Rating	IP66	
Length	300 mm	600 mm

RMF Systems Control box



START STOP BOX WITH MOTOR PROTECTION

The Start Stop box is produced according to the CE certification. This control box has an Ingress Protection Rating of IP65. Also, a motor protection relay is built in to protect the motor from overheating. The Start Stop box is supplied with 4 meter cable.

SMART CONTROL BOX

The Smart control box is IP66 rated. It makes this control box suitable for all RMF systems Smart Off-line Units. On the front of the control box, you can find the main switch, On/Off switch, emergency switch, and an emergency light indicator. The emergency light indicator lights up when the emergency switch is pressed. In the control box, you will find a motor protection relay, 24 VDC power supply for CMS, and an integrated RS485 to USB or Ethernet converter for data transfer from the CMS and OQS to your PC. The control box comes with 5 meter cable.





RMF Systems Advantages

LESS MALFUNCTIONS

The tolerances between moving parts in servo valves and proportional valves are constantly reducing. The result is that even the smallest amounts of silt can cause damage to the system. RMF filters remove this silt.

PROTECTION OF EXPENSIVE MAIN STREAM FILTERS

RMF Systems filters are applied in different Off-line configurations and constantly clean the oil from the reservoir. The oil which reaches the main stream filter is therefore cleaner and allows longer usage life of this expensive filter. The main stream filter then acts primarily as an emergency filter.

LESS FREQUENT OIL CHANGES

Increasingly strict environmental laws in the area of oil changes, oil storage and the disposal of used oil lead to

corresponding cost increases. RMF filters mean less oil changes, and therefore less costs.

EXTENDED USABLE LIFE OF THE OIL

Frequent oil changes are generally the result of chemical deterioration of the oil caused by the oil oxidation process. This process is brought into action by the presence of silt. If water is also present, this acts as a catalyst and the oxidation process is accelerated. RMF filters remove silt and water from the oil.

LESS MACHINE DOWN TIME

Reduction of defects caused by worn components and less frequent oil changes mean an increase in production time.

MEASURING POINTS

To facilitate quality control of the oil, the RMF Off-Line Oil Filters are equipped

with two quick connect measuring points to which a particle counter can be attached. This offers the possibility of measuring the oil cleanliness level on-site and under working conditions. The measuring points also allow oil samples to be drawn for external analysis.

THE SOLUTION

RMF Systems offer the most complete and efficient filter series available today. RMF Systems is the solution to your contamination problems: simple to fit, equipped with extremely efficient filters and offering the opportunity for simple control of oil cleanliness.



BSF Filbertechnik BV

T +31 180 62 13 13

T +32 3 218 62 25

E info@bsf-filtertechnik.com



www.bsf-filtertechnik.com